

# Superbolt

Multi-jackbolt tensioners (MJT) standard range





Superbolt split-nut thrust collars on forging press.

# A **revolution** in the design & tightening of bolted joints



Superbolt multi-jackbolt tensioners (MJTs) from Nord-Lock offer an innovative technology for tightening bolts & studs. Superbolt products have been proven and established as a preferred solution for bolting in every major industry, all over the world.

Our multi-jackbolt tensioners offer you simple and cost effective tightening, even for large size bolts. Your joints can be tightened with high accuracy without requiring specialist skills or heavy tooling. MJTs ensure a profitable life cycle cost by improving the bolt design for OEM manufacturers, ensuring reliable operation and by facilitating maintenance procedures.

### Complete solutions

From space to deep sea, from small to large - no matter what your bolting challenge, the Nord-Lock Group has done it before. Bring your bolting questions to us and we will work with you to find the best possible solution.

The Nord-Lock Group is your trusted partner in bolting solutions.

### Torque curve for 310 MPa (45,000 psi) bolt stress

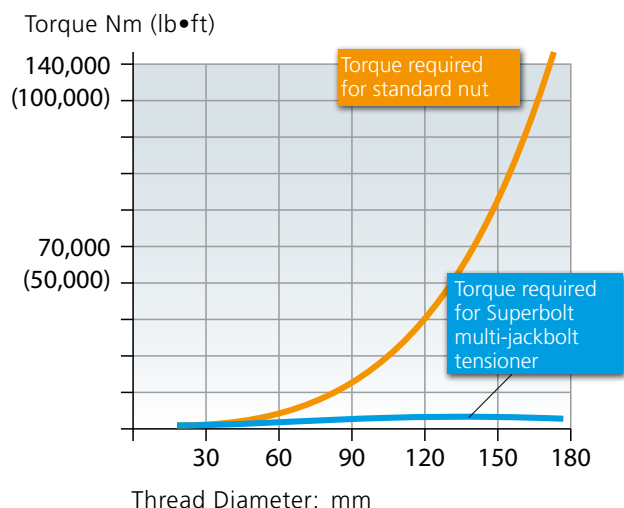

*The above chart shows how Superbolt tensioners remain easy to install, even on larger sizes, compared to standard hex nuts. Only hand tools are required to tighten any diameter stud / bolt.*

# The **innovative** bolting solution

## What is Superbolt?

Superbolt tensioners are designed as direct replacements for conventional nuts and bolts. These devices can be threaded onto a new or existing bolt, stud, threaded rod or shaft. The main thread serves to position the tensioner on the bolt or stud against the hardened washer and the load bearing surface. Once it is positioned, actual tensioning of the bolt or stud is accomplished with simple hand tools by torquing the jackbolts which encircle the main thread. The jackbolts transfer the preload evenly into the main thread and, consequently, onto the joint. The main thread is tightened in pure tension.

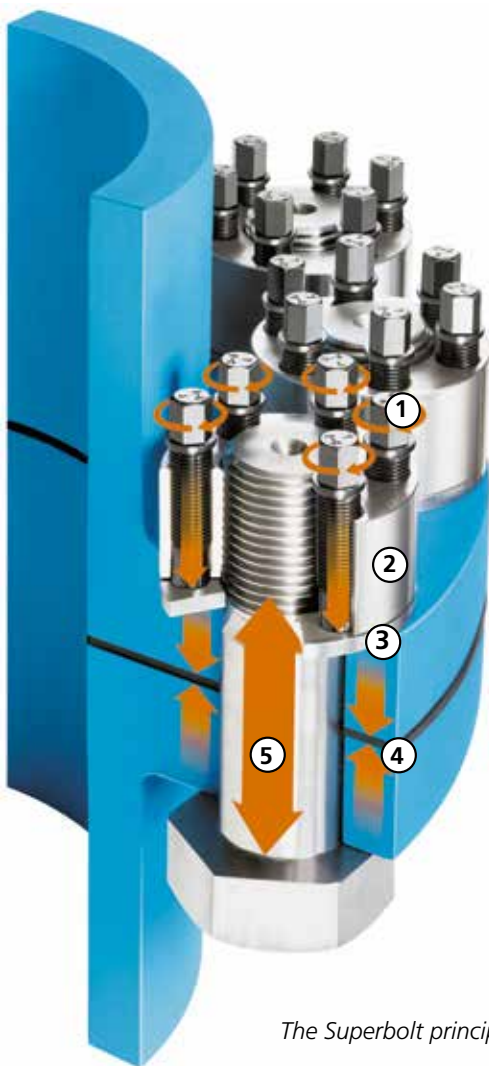

*The Superbolt principle.*

## *How Superbolt tensioners work:*

---

- 1)** By tightening the jackbolts, a strong thrust (axial) force is generated. This thrust force is directed against a hardened washer. Jackbolts have a small friction diameter and can therefore create a high thrust force with relatively little torque input.
- 2)** The loads are transferred through the nut body which is positioned on the main thread by hand.
- 3)** A hardened washer is used to transfer the force while protecting the flange face.
- 4)** The thrust (axial) force of many jackbolts and the opposite reaction force of the main bolt head create a strong clamping force on the flange.
- 5)** The thrust (axial) force from the jackbolt creates an equally strong reaction force in the main bolt.

### Proven and certified

Over the years, the product types in our wide range of multi-jackbolt tensioners have been tested and approved by several certification institutes. For some of our product series we have also achieved design and type approvals for production. Below are some examples:

- DNV (Det Norske Veritas)
- GL (Germanischer Lloyd)
- Siemens system audit

The high level of experience we have in pre-engineered products for specific challenges allows us to, upon request for certain ranges, supply certification. For example:

- TÜV
- Lloyd's Register
- Vinçotte

For more detailed information on certificates / approvals for a specific product or production site, please contact your local Nord-Lock office. Please note that the certificates you require should be requested prior to ordering to ensure we comply with your needs.

### Proven in the field

Superbolt tensioners are used in many industries: Hydropower, wind turbines, gas and steam turbines, nuclear, steel, mining, shipbuilding, offshore, chemical, transportation, to name a few.

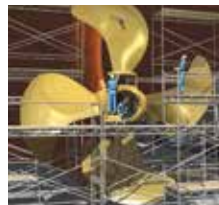

For detailed case studies, please visit [www.bolted.com](http://www.bolted.com).

# Advantages from start to finish

## Design



Our engineers can help you determine dimensions and load conditions of your bolted joints. We can evaluate your current tightening method and calculate bolt preloads necessary for reliability and durability. OEMs all over the world specify our multi-jackbolt tensioners in their design to improve the performance of their product.

### *Advantages:*

- **Higher preload** - Tightening in pure tension allows higher preloads on the same size bolt versus other tightening methods.
- **Proper bolted joint** - Generating preload high enough above the separating forces means your bolting will not vibrate loose on properly designed joints. This can eliminate costly equipment downtime.
- **Elasticity** - Added elasticity increases fatigue life of the bolted joint.
- **Design options** - High preload capacity and accuracy can allow for the design of smaller bolt sizes. Compact dimensions and reduction of tooling sizes allows for reduction of the size of machinery, reducing material and machining cost.

## First installation



The huge mechanical advantage of Superbolt products means only simple hand tools are required to tighten any size bolt or stud. Let's take a closer look at the advantages your workers will realize during installation.

### *Advantages:*

- **Hand tools only** - Ordinary hand wrenches or pneumatic wrenches are the only tools required to generate immense bolt stresses.
- **Increased safety** - Installations are safe because only small hand tools are required. This means no safety hazards from immense hydraulic pressures, pinching hazards, heavy lifting of large tools, or sockets breaking under high pressure.
- **Space restrictions** - Multi-jackbolt tensioners are easy to install in confined spaces.
- **Save time** - Superbolt tensioners can be tightened in a fraction of the time compared to most other methods. Even though there are multiple jackbolts to tighten, field experience has proven that by using air tools installation times are fast and easy. Case studies available at [www.superbolt.com](http://www.superbolt.com).

## Operation



## Maintenance

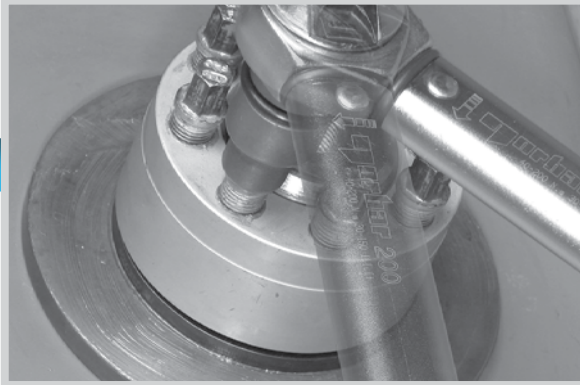

The ability to maintain necessary preload is crucial for keeping machinery running. Using multi-jackbolt technology allows proper preloading of the bolted joint in operation.

Routine equipment maintenance requires removal and re-installation of Superbolt tensioners. Using and maintaining multi-jackbolt tensioners is safe and easy.

### Advantages:





- **Accuracy** - Accurate and even tension across bolted joints reduces the tendency for leakages or uneven loading of adjacent fasteners.
- **Properly bolted** - The ability to achieve high preloads ensures a joint that does not loosen unintentionally.
- **Reliability** - Superbolt tensioners increase the fatigue life of the bolted joint.
- **Meeting your challenges** - Special designs can accommodate space restrictions or environmental / temperature conditions in any type of operating environment.
- **Downtime** - Properly designed and tightened joints will not come loose in service. This reduces downtime.

### Advantages:

- **Easy to check** - Due to the low torques required, it is easy to inspect that the joint is tight with simple torque tests using hand tools.
- **Multiple workers** - Because only hand tools are needed, multiple workers can work in conjunction when required.
- **Galling** - Tightening in pure tension eliminates thread galling that commonly occurs with direct torquing methods.
- **Removal** - Ease of removal reduces expensive downtime that can occur with standard bolting methods.
- **Reusable** - Preload can be restored almost anywhere under any conditions with simple hand tools. Superbolt tensioners are fully reusable.

# The **solution** to bolting problems

## Selection Guide

Product line	Nut-style tensioners			
Main characteristics	Standard	High strength	Medium temperatures	Medium temperatures, tall
Series	MT	CY	H650	H650T
				
Dimensional range - Metric - Imperial	M16-M160 3/4" – 6"	M16-M160 3/4" – 6"	M20-M125 3/4" – 5"	M24-M100 1" – 4"
Approximate bolt stress depending on size	450 to 700 N/mm <sup>2</sup> 60 to 100 ksi	500 to 900 N/mm <sup>2</sup> 70 to 130 ksi	310 N/mm <sup>2</sup> 45 ksi <i>Based on stress area As</i>	310 N/mm <sup>2</sup> 45 ksi <i>Based on stress area As</i>
Temperature range	-10 to 250 °C 0 to 500 °F	-40 to 250 °C -50 to 500 °F <i>Lower temperatures on demand</i>	Up to 350 °C Up to 650 °F	Up to 350 °C Up to 650 °F
Surface treatment	Optional	Optional	Optional	Optional
Application samples	Bolting applications in demanding industries.	Similar to MT, but for higher strength.	Large studs on: - Boiler feed pumps - Boiler circulating pumps - Reactors - Heat exchangers Etc.	Split lines on: - Turbines - Engines - Pumps - Compressors Etc.
Jackbolt lubricant	JL-G or JL-AS	JL-G or JL-AS	JL-G or P37	JL-G or P37
Note	Equivalent bolt-style tensioner: SB8	Equivalent bolt-style tensioner: SB12	—	Also for applications with limited space in diameter
See page	12	13	14	15



Compact	Bolt-style tensioners		Flexnuts	
	Standard	High strength	Standard	High strength
SJ	SB8	SB12	SX8	SX12
				
M20–M160 3/4" – 6"	M16–M160 3/4" – 6"	M20–M90 3/4" – 3-1/2"	M20–M160 3/4" – 6"	M20–M160 3/4" – 6"
250 to 400 N/mm <sup>2</sup> 35 to 60 ksi	400 to 650 N/mm <sup>2</sup> 60 to 95 ksi	500 to 850 N/mm <sup>2</sup> 70 to 125 ksi	450 to 700 N/mm <sup>2</sup> 60 to 100 ksi	500 to 900 N/mm <sup>2</sup> 70 to 130 ksi
-10 to 250 °C 0 to 500 °F	-10 to 250 °C 0 to 500 °F	-10 to 250 °C 0 to 500 °F <i>Lower temperatures on demand</i>	-10 to 250 °C 0 to 500 °F	-40 to 250 °C -50 to 500 °F <i>Lower temperatures on demand</i>
Optional	Optional	Optional	Optional	Optional
Limited height: - Hydraulic cylinders - Shaft mounts - Piston connections - Foundations Etc.	Bolting applications in demanding industries.	Similar to SB8, but for higher strength.	Reactive nut for through hole applications. Adds elasticity to bolted joints. Highly recommended for short clamp lengths.	Similar to SX8, but for higher strength.
JL-G or JL-AS	JL-G or JL-AS	JL-G or JL-AS	-	-
—	Equivalent nut-style tensioner: MT	Equivalent nut-style tensioner: CY	In combination with MT nut-style tensioners or SB8 bolt-style tensioners	In combination with CY nut-style tensioners or SB12 bolt-style tensioners
16	18	19	20	21

### Special products when the application requires it

We additionally offer a wide range of pre-engineered solutions, including special material and designs. We have made specials up to diameter 1500 mm and products for operating temperatures of 700 °C (1292 °F). Our expertise is unique in the market, see pages 24–25 for some examples of case studies. We also have series developed especially for specific industries. For applications where the above standard range does not meet your requirements, our Performance Services team will work with you to find the optimum solution (see pages 26-27).

# World class manufacturing



The Nord-Lock Group has invested heavily in the Superbolt manufacturing facilities, which include world class CNC machining operations. Our capacity for machining allows quick turnaround of standard and special multi-jackbolt tensioners and other related bolting products.



Most standard products are available off the shelf or in a short lead time. In addition, the engineering, manufacturing and production personnel have accumulated decades of knowledge and training in producing some of the finest threaded components and products in the world.

## Quality and traceability

Special attention has been paid over the years to developing and implementing our quality systems to work on highly critical and demanding industries. Quality control, including thread gauging and measurement systems, is standard operating procedure.

Multi-jackbolt tensioner nut and bolt bodies are marked for traceability.

### Example of part marking information

SUPERBOLT
Part number: MF-M36x4
Lot number: 7900
Max. load: 457 kN
Material code: CrMo

*Note: Information may vary. Custom markings possible upon request. For further information, contact your local Nord-Lock office.*



# Overview of part names

On every part delivered you can always ensure that you have received the right product, including the following information. The marking system on our products is explained in the below tables.

Standard, Metric		MT - M 120x6 x ..... /W			
<b>Type/series</b>					
MT	Nut-style tensioner, standard				
CY	Nut-style tensioner, high strength				
SJ	Nut-style tensioner, compact				
H650	Nut-style tensioner, medium temperature				
H650T	Nut-style tensioner, medium temperature, tall, slim O.D.				
SX8	Flexnut, standard				
SX12	Flexnut, high strength				
SB8	Bolt-style tensioner, standard				
SB12	Bolt-style tensioner, high strength				
<b>Standard thread profile</b>					
M	Metric				
<b>Thread size</b>					
$d_0 \times p$	nominal diameter x pitch				
<b>Nominal length L</b> (see sketches on pages 18 & 19) [mm]					
Washer					

Standard, Imperial		MT - 112 - 7 UNC x ..... /W			
<b>Type/series</b> (same as above)					
<b>Thread size</b> (nominal diameter $d_0$ )					
xxx...	decimal, rounded to 2 decimal digits x 100				
<b>Threads per inch</b> (tpi)					
<b>Standard thread profiles</b>					
UN, UNC,	Unified according to ANSI B1.1				
UNF					
<b>Nominal length L</b> (see sketches on pages 18 & 19) [inch] decimal, rounded to 2 decimal digits					
Washer					

Specials		MT - .....	
<b>Type/series</b>			
<b>Special designation number</b>			

All threads are available upon request. Examples:

A	Acme (please specify standard)	Rd	Round (please specify standard)
S	Buttress (please specify standard)	Tr	Trapezoidal (please specify standard)
W	Metric Whitworth	BSW / BSF	Whitworth threads

Our sales engineers are standing by to help you identify the best product for your application. Please contact your local Nord-Lock office.

# MT

## Superbolt nut-style tensioner, standard

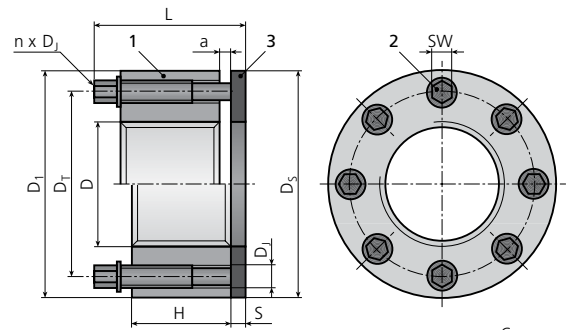

- Components:  
 1 Nut body  
 2 Jackbolts  
 3 Hardened washer

METRIC Part No.	Size			Nut body			Jackbolt				Hardened washer		Height tot. L [mm]	Weight [kg]	Preload total		Torque per Jackbolt		
	Thread D	Available Pitch P <sub>1</sub> P <sub>2</sub> P <sub>3</sub> [mm]			D <sub>1</sub>	H	D <sub>T</sub>	D <sub>J</sub>	n	SW	a	D <sub>S</sub>			S	nom. F <sub>1</sub>	max. F <sub>2</sub>	nom. M <sub>1</sub>	max. M <sub>2</sub>
MT-M16x...W	M16	2	1.5	1	34	16	25	M6x0.75	4	5	6	32	3	33	0.11	73	94	14	18
MT-M20x...W	M20	2.5	1.5	1	38	16	29	M6x0.75	6	5	6	38	4	34	0.14	110	140	14	18
MT-M22x...W	M22	2.5	1.5	1	41	16	31	M6x0.75	6	5	6	41	4	34	0.16	110	140	14	18
MT-M24x...W	M24	3	2	1.5	44	16	33	M6x0.75	8	5	6	43	4	34	0.19	145	187	14	18
MT-M27x...W	M27	3	2	1.5	50	24	39	M8x1	6	6	6	50	5	45	0.35	214	285	36	48
MT-M30x...W	M30	3.5	2	1.5	53	24	42	M8x1	6	6	6	53	5	45	0.37	214	285	36	48
MT-M33x...W	M33	3.5	2	1.5	59	24	45	M8x1	8	6	6	59	5	45	0.48	285	380	36	48
MT-M36x...W	M36	4	3	1.5	66	32	51	M10x1.25	6	8	8	66	5	57	0.76	343	457	72	96
MT-M39x...W	M39	4	3	1.5	70	32	54	M10x1.25	8	8	8	70	5	57	0.90	457	610	72	96
MT-M42x...W	M42	4.5	3	1.5	75	32	57	M10x1.25	8	8	8	73	5	57	1.01	457	610	72	96
MT-M45x...W	M45	4.5	3	1.5	83	38	63	M12x1.25	8	10	10	81	6	68	1.48	700	935	131	175
MT-M48x...W	M48	5	3	1.5	85	38	66	M12x1.25	8	10	10	85	6	68	1.50	700	935	131	175
MT-M52x...W	M52	5	3	2	94	38	70	M12x1.25	8	10	10	89	6	68	1.80	700	935	131	175
MT-M56x...W	M56	5.5	4	2	100	38	76	M12x1.25	8	10	10	95	6	68	2.00	700	935	131	175
MT-M60x...W	M60	5.5	4	2	107	38	78	M12x1.25	10	10	10	100	6	68	2.30	875	1160	131	175
MT-M64x...W	M64	6	4	2	113	53	87	M16x1.5	8	14	12	112	8	92	3.65	1270	1690	315	420
MT-M68x...W	M68	6	4	2	117	53	91	M16x1.5	8	14	12	117	8	92	3.85	1270	1690	315	420
MT-M72x...W	M72	6	4	2	120	56	95	M16x1.5	8	14	9	120	8	92	4.00	1270	1690	315	420
MT-M76x...W	M76	6	4	2	132	56	100	M16x1.5	12	14	9	127	8	92	5.10	1900	2530	315	420
MT-M80x...W	M80	6	4	2	132	56	103	M16x1.5	12	14	9	127	8	92	4.80	1900	2530	315	420
MT-M85x...W	M85	6	4	2	137	56	108	M16x1.5	12	14	9	137	8	92	5.10	1900	2530	315	420
MT-M90x...W	M90	6	4	2	145	59	113	M16x1.5	16	14	13	140	8	99	6.00	2530	3380	315	420
MT-M100x...W	M100	6	4	2	164	61	123	M16x1.5	16	14	11	152	8	99	7.80	2530	3380	315	420
MT-M110x...W	M110	6	4	2	177	79	139	M20x1.5	12	17	16	172	10	125	11.40	3150	4200	645	860
MT-M120x...W	M120	6	4	2	189	81	149	M20x1.5	16	17	14	179	10	125	13.00	4200	5600	645	860
MT-M125x...W	M125	6	4	2	194	81	154	M20x1.5	16	17	14	190	10	125	13.50	4200	5600	645	860
MT-M130x...W	M130	6	4	2	205	94	159	M20x1.5	18	17	16	202	10	140	17.50	4700	6300	645	860
MT-M140x...W	M140	6	4	2	215	94	169	M20x1.5	20	17	16	215	10	140	18.70	5250	7000	645	860
MT-M150x...W	M150	6	4	2	225	94	179	M20x1.5	20	17	16	225	12	142	20.00	5250	7000	645	860
MT-M160x...W	M160	6	4	-	234	107	189	M20x1.5	24	17	23	234	12	162	24.10	6300	8400	645	860

IMPERIAL Part No.	Size			Nut body			Jackbolt				Hardened washer		Height tot. L [In]	Weight [Lb]	Preload total		Torque per Jackbolt		
	Thread D [In]	TPI <sub>1</sub>	TPI <sub>2</sub>	TPI <sub>3</sub>	D <sub>1</sub>	H	D <sub>T</sub>	D <sub>J</sub>	n	SW	a	D <sub>S</sub>			S	nom. F <sub>1</sub>	max. F <sub>2</sub>	nom. M <sub>1</sub>	max. M <sub>2</sub>
MT-075-...W	3/4	10	16	-	1.47	0.70	1.13	1/4-28	4	3/16	0.24	1.50	0.13	1.38	0.31	20400	27200	14	18
MT-087-...W	7/8	9	14	-	1.60	0.70	1.26	1/4-28	6	3/16	0.24	1.63	0.13	1.38	0.34	30600	40800	14	18
MT-100-...W	1	8	12	14	1.90	0.93	1.46	5/16-24	6	1/4	0.20	2.00	0.19	1.71	0.68	48600	64800	27	36
MT-112-...W	1-1/8	7	8	12	2.08	0.93	1.59	5/16-24	6	1/4	0.20	2.13	0.19	1.71	0.79	48600	64800	27	36
MT-125-...W	1-1/4	7	8	12	2.25	0.94	1.75	5/16-24	8	1/4	0.19	2.38	0.19	1.71	0.92	64800	86400	27	36
MT-137-...W	1-3/8	6	8	12	2.46	1.20	1.94	3/8-24	6	5/16	0.25	2.50	0.19	2.12	1.40	73800	98400	49	65
MT-150-...W	1-1/2	6	8	12	2.70	1.20	2.07	3/8-24	8	5/16	0.25	2.75	0.19	2.12	1.70	98400	131200	49	65
MT-162-...W	1-5/8	6	8	12	2.96	1.20	2.20	3/8-24	8	5/16	0.25	2.88	0.19	2.12	2.01	98400	131200	49	65
MT-175-...W	1-3/4	5	8	12	3.08	1.42	2.38	7/16-20	8	3/8	0.28	3.13	0.25	2.49	2.53	129600	172800	75	100
MT-187-...W	1-7/8	6	8	12	3.59	1.60	2.74	1/2-20	8	7/16	0.40	3.50	0.25	2.85	4.07	175200	233600	114	152
MT-200-...W	2	4.5	8	12	3.59	1.60	2.74	1/2-20	8	7/16	0.40	3.50	0.25	2.85	3.87	175200	233600	114	152
MT-225-...W	2-1/4	4.5	8	12	3.95	1.60	3.00	1/2-20	8	7/16	0.40	3.75	0.25	2.85	4.51	175200	233600	114	152
MT-250-...W	2-1/2	4	8	12	4.45	2.10	3.43	5/8-18	8	9/16	0.45	4.50	0.31	3.61	7.82	285600	380800	233	310
MT-275-...W	2-3/4	4	8	12	4.70	2.10	3.69	5/8-18	8	9/16	0.45	4.75	0.31	3.61	8.36	285600	380800	233	310
MT-300-...W	3	4	6	8	5.20	2.10	3.95	5/8-18	12	9/16	0.45	5.00	0.31	3.61	10.30	428400	571200	233	310
MT-325-...W	3-1/4	4	6	8	5.45	2.20	4.15	5/8-18	12	9/16	0.35	5.00	0.31	3.61	11.04	428400	571200	233	310
MT-350-...W	3-1/2	4	6	8	5.70	2.30	4.40	5/8-18	16	9/16	0.51	5.50	0.31	3.87	12.62	571200	761600	233	310
MT-375-...W	3-3/4	4	6	8	6.20	2.40	4.65	5/8-18	16	9/16	0.41	5.50	0.31	3.87	15.08	571200	761600	233	310
MT-400-...W	4	4	6	8	6.45	2.60	4.90	5/8-18	18	9/16	0.53	6.00	0.31	4.19	17.31	642600	856800	233	310
MT-425-...W	4-1/4	4	6	8	6.95	3.00	5.33	3/4-16	16	5/8	0.50	6.40	0.38	4.76	23.41	806400	1075200	390	520
MT-450-...W	4-1/2	4	6	8	7.20	3.00	5.58	3/4-16	16	5/8	0.50	6.65	0.38	4.76	24.44	806400	1075200	390	520
MT-475-...W	4-3/4	4	6	8	7.45	3.20	5.83	3/4-16	18	5/8	0.60	6.90	0.38	5.06	27.13	907200	1209600	390	520
MT-500-...W	5	4	6	8	7.70	3.30	6.08	3/4-16	20	5/8	0.50	7.15	0.38	5.06	28.83	1008000	1344000	390	520
MT-525-...W	5-1/4	4	6	8	8.45	3.70	6.58	3/4-16	22	5/8	0.40	7.65	0.38	5.36	40.06	1108800	1478400	390	520
MT-550-...W	5-1/2	4	6	8	8.45	3.70	6.58	3/4-16	22	5/8	0.40	7.65	0.38	5.36	37.56	1108800	1478400	390	520
MT-575-...W	5-3/4	4	6	8	8.95	4.00	7.11	3/4-16	24	5/8	0.50	8.15	0.38	5.76	46.26	1209600	1612800	390	520
MT-600-...W	6	4	6	8	8.95	4.00	7.11	3/4-16	24	5/8	0.50	8.15	0.38	5.76	43.32	1209600	1612800	390	520

- Note:
- Maximum values valid for permanent bolting applications, including reaction forces.
  - Other sizes, thread pitches or threads per inch (TPI) may be available. Please contact your local Nord-Lock office.
  - Dimensions listed are representative. Typical manufacturing tolerances apply (approximately within 1mm or 1%).

# CY

## Superbolt nut-style tensioner, high strength

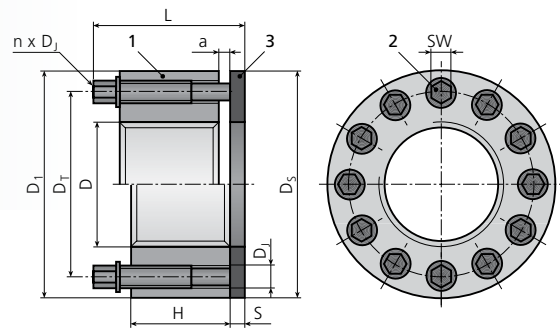

- Components:  
 1 Nut body  
 2 Jackbolts  
 3 Hardened washer

METRIC	Size			Nut body			Jackbolt				Hardened washer		Height tot. L [mm]	Weight [kg]	Preload total		Torque per Jackbolt		
	Part No.	Thread D	Available Pitch P <sub>1</sub> P <sub>2</sub> P <sub>3</sub> [mm]	D <sub>1</sub>	H [mm]	D <sub>2</sub>	D <sub>3</sub> [mm]	n	SW [mm]	a [mm]	D <sub>4</sub> [mm]	S			nom. F <sub>1</sub> [kN]	max. F <sub>2</sub> [kN]	nom. M <sub>1</sub> [Nm]	max. M <sub>2</sub> [Nm]	
CY-M16x...W	M16	2	1.5	1	34	16	25	M6x0.75	6	5	6	32	3	33	0.12	110	140	14	18
CY-M20x...W	M20	2.5	1.5	1	38	17	29	M6x0.75	8	5	5	38	4	34	0.15	145	185	14	18
CY-M22x...W	M22	2.5	1.5	1	41	17	31	M6x0.75	8	5	5	41	4	34	0.17	145	185	14	18
CY-M24x...W	M24	3	2	1.5	47	24	36	M8x1	6	6	6	47	4	44	0.30	215	285	36	48
CY-M27x...W	M27	3	2	1.5	51	24	39	M8x1	8	6	6	50	5	45	0.37	285	380	36	48
CY-M30x...W	M30	3.5	2	1.5	54	24	42	M8x1	8	6	6	53	5	45	0.38	285	380	36	48
CY-M33x...W	M33	3.5	2	1.5	62	32	48	M10x1.25	6	8	8	61	5	57	0.70	345	460	72	96
CY-M36x...W	M36	4	3	1.5	66	32	51	M10x1.25	8	8	8	66	5	57	0.79	455	610	72	96
CY-M39x...W	M39	4	3	1.5	72	32	54	M10x1.25	10	8	8	70	5	57	0.97	570	760	72	96
CY-M42x...W	M42	4.5	3	1.5	76	32	57	M10x1.25	12	8	8	73	5	57	1.10	685	915	72	96
CY-M45x...W	M45	4.5	3	1.5	81	38	62	M12x1.25	8	10	10	80	6	68	1.40	700	935	131	175
CY-M48x...W	M48	5	3	1.5	85	38	66	M12x1.25	10	10	10	85	6	68	1.54	875	1170	131	175
CY-M52x...W	M52	5	3	2	94	38	70	M12x1.25	12	10	10	90	6	68	1.80	1050	1400	131	175
CY-M56x...W	M56	5.5	4	2	98	38	74	M12x1.25	12	10	10	94	6	68	1.93	1050	1400	131	175
CY-M60x...W	M60	5.5	4	2	107	59	83	M16x1.5	8	14	13	106	8	99	3.70	1270	1670	315	420
CY-M64x...W	M64	6	4	2	113	59	87	M16x1.5	10	14	13	112	8	99	4.10	1580	2100	315	420
CY-M68x...W	M68	6	4	2	117	59	91	M16x1.5	12	14	13	117	8	99	4.30	1900	2530	315	420
CY-M72x...W	M72	6	4	2	121	59	95	M16x1.5	12	14	13	120	8	99	4.50	1900	2530	315	420
CY-M76x...W	M76	6	4	2	132	61	102	M16x1.5	16	14	11	127	8	99	5.60	2530	3370	315	420
CY-M80x...W	M80	6	4	2	133	61	103	M16x1.5	16	14	11	127	8	99	5.40	2530	3370	315	420
CY-M85x...W	M85	6	4	2	139	61	108	M16x1.5	16	14	11	137	8	99	5.80	2530	3370	315	420
CY-M90x...W	M90	6	4	2	145	61	113	M16x1.5	16	14	11	140	8	99	6.30	2530	3370	315	420
CY-M100x...W	M100	6	4	2	157	61	123	M16x1.5	16	14	11	152	8	99	7.00	2530	3370	315	420
CY-M110x...W	M110	6	4	2	177	61	133	M16x1.5	20	14	11	163	8	99	9.00	3180	4200	315	420
CY-M120x...W	M120	6	4	2	189	81	149	M20x1.5	18	17	14	179	10	125	13.10	4700	6300	645	860
CY-M125x...W	M125	6	4	2	194	81	154	M20x1.5	18	17	14	190	10	125	13.70	4700	6300	645	860
CY-M130x...W	M130	6	4	2	205	94	159	M20x1.5	20	17	16	202	10	140	17.60	5250	7000	645	860
CY-M140x...W	M140	6	4	2	215	94	169	M20x1.5	22	17	16	215	10	140	18.89	5750	7700	645	860
CY-M150x...W	M150	6	4	2	225	94	179	M20x1.5	22	17	16	225	12	142	20.10	5750	7700	645	860
CY-M160x...W	M160	6	4	-	226	107	189	M20x1.5	24	17	23	220	10	160	20.80	6300	8400	645	860

IMPERIAL	Size			Nut body			Jackbolt				Hardened washer		Height tot. L [in]	Weight [Lb]	Preload total		Torque per Jackbolt		
	Part No.	Thread D [in]	Available TPI TPI <sub>1</sub> TPI <sub>2</sub> TPI <sub>3</sub>	D <sub>1</sub>	H [in]	D <sub>2</sub>	D <sub>3</sub> [in]	n	SW [in]	a [in]	D <sub>4</sub> [in]	S			nom. F <sub>1</sub> [Lb]	max. F <sub>2</sub> [Lb]	nom. M <sub>1</sub> [Lbft]	max. M <sub>2</sub> [Lbft]	
CY-075...W	3/4	10	16	-	1.47	0.70	1.13	1/4-28	6	3/16	0.24	1.50	0.13	1.38	0.31	30600	40800	14	18
CY-087...W	7/8	9	14	-	1.70	0.70	1.26	1/4-28	8	3/16	0.24	1.63	0.13	1.38	0.39	40800	54400	14	18
CY-100...W	1	8	12	14	1.90	0.93	1.46	5/16-24	6	1/4	0.20	2.00	0.19	1.71	0.68	48600	64800	27	36
CY-112...W	1-1/8	7	8	12	2.08	0.93	1.59	5/16-24	8	1/4	0.20	2.13	0.19	1.71	0.78	64800	86400	27	36
CY-125...W	1-1/4	7	8	12	2.32	1.20	1.81	3/8-24	6	5/16	0.25	2.38	0.19	2.12	1.30	73800	98400	49	65
CY-137...W	1-3/8	6	8	12	2.46	1.20	1.92	3/8-24	8	5/16	0.25	2.50	0.19	2.12	1.42	98400	131200	49	65
CY-150...W	1-1/2	6	8	12	2.80	1.42	2.13	7/16-20	8	3/8	0.28	2.75	0.19	2.43	2.11	129600	172800	75	100
CY-162...W	1-5/8	6	8	12	2.96	1.42	2.26	7/16-20	8	3/8	0.28	2.88	0.19	2.43	2.29	129600	172800	75	100
CY-175...W	1-3/4	5	8	12	3.20	1.42	2.38	7/16-20	12	3/8	0.28	3.13	0.25	2.49	2.80	194400	259200	75	100
CY-187...W	1-7/8	6	8	12	3.59	1.60	2.74	1/2-20	8	7/16	0.40	3.50	0.25	2.85	4.07	175200	233600	114	152
CY-200...W	2	4.5	8	12	3.70	1.60	2.74	1/2-20	12	7/16	0.40	3.50	0.25	2.85	4.24	262800	350400	114	152
CY-225...W	2-1/4	4.5	8	12	3.95	1.60	3.00	1/2-20	12	7/16	0.40	3.75	0.25	2.85	4.59	262800	350400	114	152
CY-250...W	2-1/2	4	8	12	4.45	2.30	3.43	5/8-18	12	9/16	0.51	4.50	0.31	3.87	8.64	428400	571200	233	310
CY-275...W	2-3/4	4	8	12	4.70	2.40	3.69	5/8-18	12	9/16	0.41	4.75	0.31	3.87	9.45	428400	571200	233	310
CY-300...W	3	4	6	8	5.20	2.30	3.95	5/8-18	16	9/16	0.51	5.00	0.31	3.87	11.33	571200	761600	233	310
CY-325...W	3-1/4	4	6	8	5.45	2.30	4.15	5/8-18	16	9/16	0.51	5.00	0.31	3.87	11.79	571200	761600	233	310
CY-350...W	3-1/2	4	6	8	5.70	2.40	4.40	5/8-18	18	9/16	0.41	5.50	0.31	3.87	13.02	642600	856800	233	310
CY-375...W	3-3/4	4	6	8	5.95	2.40	4.65	5/8-18	18	9/16	0.41	5.50	0.31	3.87	13.49	642600	856800	233	310
CY-400...W	4	4	6	8	6.20	2.60	4.90	5/8-18	20	9/16	0.53	6.00	0.31	4.19	15.50	714000	952000	233	310
CY-425...W	4-1/4	4	6	8	6.95	3.00	5.33	3/4-16	18	5/8	0.50	6.40	0.38	4.76	23.50	907200	1209600	390	520
CY-450...W	4-1/2	4	6	8	7.20	3.00	5.58	3/4-16	18	5/8	0.50	6.65	0.38	4.76	24.53	907200	1209600	390	520
CY-475...W	4-3/4	4	6	8	7.45	3.20	5.83	3/4-16	20	5/8	0.60	6.90	0.38	5.06	29.90	1008000	1344000	390	520
CY-500...W	5	4	6	8	7.70	3.30	6.08	3/4-16	20	5/8	0.50	7.15	0.38	5.06	28.83	1008000	1344000	390	520
CY-525...W	5-1/4	4	6	8	7.95	3.70	6.58	3/4-16	22	5/8	0.40	7.65	0.38	5.36	33.12	1108800	1478400	390	520
CY-550...W	5-1/2	4	6	8	7.95	3.70	6.58	3/4-16	22	5/8	0.40	7.65	0.38	5.36	30.62	1108800	1478400	390	520
CY-575...W	5-3/4	4	6	8	8.45	4.00	7.08	3/4-16	24	5/8	0.50	8.15	0.38	5.76	38.31	1209600	1612800	390	520
CY-600...W	6	4	6	8	8.45	4.00	7.08	3/4-16	24	5/8	0.50	8.15	0.38	5.76	35.36	1209600	1612800	390	520

- Note:
- Maximum values valid for permanent bolting applications, including reaction forces.
  - Other sizes, thread pitches or threads per inch (TPI) may be available. Please contact your local Nord-Lock office.
  - Dimensions listed are representative. Typical manufacturing tolerances apply (approximately within 1mm or 1%).

# H650

Superbolt nut-style tensioner,  
for medium temperatures

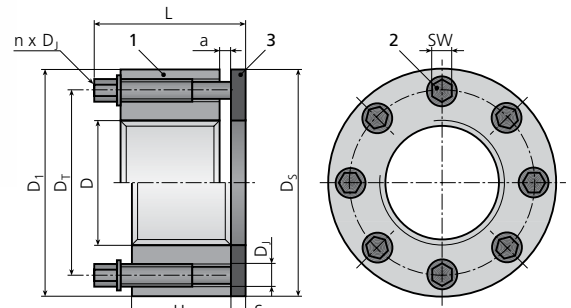

- Components:  
1 Nut body  
2 Jackbolts  
3 Hardened washer

METRIC	Size			Nut body			Jackbolt				Hardened washer		Height tot. L [mm]	Weight [kg]	Preload total nom. F <sub>1</sub> [kN]	Torque per Jackbolt nom. M <sub>1</sub> [Nm]	
	Part No.	Thread D	Available Pitch P <sub>1</sub> P <sub>2</sub> P <sub>3</sub> [mm]			D <sub>1</sub>	H	D <sub>T</sub>	D <sub>J</sub>	n	SW	a					D <sub>S</sub>
H650-M20x...W	M20	2.5	1.5	1	38	16	29	M6x0.75	6	5	6	38	4	34	0.14	75	10
H650-M22x...W	M22	2.5	1.5	1	41	16	31	M6x0.75	6	5	6	41	4	34	0.16	94	12
H650-M24x...W	M24	3	2	1.5	44	16	33	M6x0.75	8	5	6	43	4	34	0.19	110	11
H650-M27x...W	M27	3	2	1.5	50	24	39	M8x1	6	6	6	50	5	45	0.35	140	24
H650-M30x...W	M30	3.5	2	1.5	53	24	42	M8x1	6	6	6	53	5	45	0.37	175	30
H650-M33x...W	M33	3.5	2	1.5	59	24	45	M8x1	8	6	6	59	5	45	0.48	215	27
H650-M36x...W	M36	4	3	1.5	66	32	51	M10x1.25	6	8	8	66	5	57	0.76	255	53
H650-M39x...W	M39	4	3	1.5	70	32	54	M10x1.25	8	8	8	70	5	57	0.90	300	47
H650-M42x...W	M42	4.5	3	1.5	75	32	57	M10x1.25	8	8	8	73	5	57	1.01	350	55
H650-M45x...W	M45	4.5	3	1.5	83	38	63	M12x1.25	8	10	10	81	6	68	1.48	405	75
H650-M48x...W	M48	5	3	1.5	85	38	66	M12x1.25	8	10	10	85	6	68	1.50	455	85
H650-M52x...W	M52	5	3	2	94	38	70	M12x1.25	8	10	10	89	6	68	1.80	540	100
H650-M56x...W	M56	5.5	4	2	100	38	76	M12x1.25	8	10	10	95	6	68	2.00	630	120
H650-M60x...W	M60	5.5	4	2	107	38	78	M12x1.25	10	10	10	100	6	68	2.30	740	110
H650-M64x...W	M64	6	4	2	113	53	87	M16x1.5	8	14	12	112	8	92	3.65	830	205
H650-M72x...W	M72	6	4	2	120	56	95	M16x1.5	8	14	9	120	8	92	4.00	1070	265
H650-M76x...W	M76	6	4	2	132	56	100	M16x1.5	12	14	9	127	8	92	5.10	1200	200
H650-M80x...W	M80	6	4	2	132	56	103	M16x1.5	12	14	9	127	8	92	4.80	1330	220
H650-M90x...W	M90	6	4	2	145	59	113	M16x1.5	16	14	13	140	8	99	6.00	1730	215
H650-M100x...W	M100	6	4	2	164	61	123	M16x1.5	16	14	11	152	8	99	7.80	2170	270
H650-M110x...W	M110	6	4	2	177	79	139	M20x1.5	12	17	16	172	10	125	11.40	2650	550
H650-M120x...W	M120	6	4	2	189	81	149	M20x1.5	16	17	14	179	10	125	13.00	3210	500
H650-M125x...W	M125	6	4	2	194	81	154	M20x1.5	16	17	14	190	10	125	13.50	3470	540

IMPERIAL	Size			Nut body			Jackbolt				Hardened washer		Height tot. L [in]	Weight [Lb]	Preload total nom. F <sub>1</sub> [Lb]	Torque per Jack- bolt nom. M <sub>1</sub> [Lbft]	
	Part No.	Thread D [in]	Available TPI TPI <sub>1</sub> TPI <sub>2</sub> TPI <sub>3</sub>			D <sub>1</sub>	H	D <sub>T</sub>	D <sub>J</sub>	n	SW	a					D <sub>S</sub>
H650-075...W	3/4	10	16	-	1.47	.70	1.132	1/4-28	4	3/16	0.24	1.50	0.13	1.38	0.31	13950	9
H650-087...W	7/8	9	14	-	1.60	.70	1.262	1/4-28	6	3/16	0.24	1.63	0.13	1.38	0.34	19790	9
H650-100...W	1	8	12	14	1.90	.93	1.456	5/16-24	6	1/4	0.20	2.00	0.19	1.71	0.68	27260	15
H650-112...W	1-1/8	7	8	12	2.08	.93	1.585	5/16-24	6	1/4	0.20	2.13	0.19	1.71	0.79	35570	20
H650-125...W	1-1/4	7	8	12	2.25	.94	1.747	5/16-24	8	1/4	0.19	2.38	0.19	1.71	0.92	44990	19
H650-137...W	1-3/8	6	8	12	2.46	1.20	1.941	3/8-24	6	5/16	0.25	2.50	0.19	2.12	1.40	55510	37
H650-150...W	1-1/2	6	8	12	2.70	1.20	2.070	3/8-24	8	5/16	0.25	2.75	0.19	2.12	1.70	67130	33
H650-162...W	1-5/8	6	8	12	2.96	1.20	2.200	3/8-24	8	5/16	0.25	2.88	0.19	2.12	2.01	79860	40
H650-175...W	1-3/4	5	8	12	3.08	1.42	2.381	7/16-20	8	3/8	0.28	3.13	0.25	2.49	2.53	93700	54
H650-187...W	1-7/8	6	8	12	3.59	1.60	2.743	1/2-20	8	7/16	0.40	3.50	0.25	2.85	4.07	108600	71
H650-200...W	2	4.5	8	12	3.59	1.60	2.743	1/2-20	8	7/16	0.40	3.50	0.25	2.85	3.87	124700	81
H650-225...W	2-1/4	4.5	8	12	3.95	1.60	3.003	1/2-20	8	7/16	0.40	3.75	0.25	2.85	4.51	160100	104
H650-250...W	2-1/2	4	8	12	4.45	2.10	3.429	5/8-18	8	9/16	0.45	4.50	0.31	3.61	7.82	199900	163
H650-275...W	2-3/4	4	8	12	4.70	2.10	3.688	5/8-18	8	9/16	0.45	4.75	0.31	3.61	8.36	244100	199
H650-300...W	3	4	6	8	5.20	2.10	3.947	5/8-18	12	9/16	0.45	5.00	0.31	3.61	10.30	292800	159
H650-325...W	3-1/4	4	6	8	5.45	2.20	4.150	5/8-18	12	9/16	0.35	5.00	0.31	3.61	11.04	345900	188
H650-350...W	3-1/2	4	6	8	5.70	2.30	4.400	5/8-18	16	9/16	0.51	5.50	0.31	3.87	12.62	403300	164
H650-375...W	3-3/4	4	6	8	6.20	2.40	4.650	5/8-18	16	9/16	0.41	5.50	0.31	3.87	15.08	465300	189
H650-400...W	4	4	6	8	6.45	2.60	4.900	5/8-18	18	9/16	0.53	6.00	0.31	4.19	17.31	531600	192
H650-425...W	4-1/4	4	6	8	6.95	3.00	5.330	3/4-16	16	5/8	0.50	6.40	0.38	4.76	23.41	602300	291
H650-450...W	4-1/2	4	6	8	7.20	3.00	5.580	3/4-16	16	5/8	0.50	6.65	0.38	4.76	24.44	677500	328
H650-475...W	4-3/4	4	6	8	7.45	3.20	5.830	3/4-16	18	5/8	0.60	6.90	0.38	5.06	27.13	757100	326
H650-500...W	5	4	6	8	7.70	3.30	6.080	3/4-16	20	5/8	0.50	7.15	0.38	5.06	28.83	841100	325

Note: - Other sizes, thread pitches or threads per inch (TPI) may be available. Please contact your local Nord-Lock office.  
- Dimensions listed are representative. Typical manufacturing tolerances apply (approximately within 1mm or 1%).

# H650T

Superbolt nut-style tensioner,  
for medium temperatures, tall

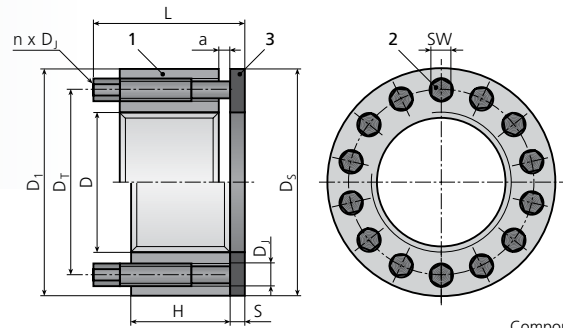

- Components:  
1 Nut body  
2 Jackbolts  
3 Hardened washer

METRIC	Size				Nut body			Jackbolt				Hardened washer		Height tot. L [mm]	Weight [kg]	Preload total nom. F <sub>1</sub> [kN]	Torque per Jackbolt nom. M <sub>1</sub> [Nm]
	Part No.	Thread D	Available Pitch P <sub>1</sub> P <sub>2</sub> P <sub>3</sub> [mm]			D <sub>1</sub>	H	D <sub>T</sub>	D <sub>j</sub>	n	SW	a	D <sub>s</sub>				
H650T-M24x...W	M24	3	2	1.5	41	28	32	M6x0.75	8	5	4	40	3	43	0.20	110	11
H650T-M27x...W	M27	3	2	1.5	43	28	35	M6x0.75	10	5	4	43	3	43	0.25	140	11
H650T-M30x...W	M30	3.5	2	1.5	46	28	38	M6x0.75	12	5	4	46	3	43	0.25	175	11
H650T-M33x...W	M33	3.5	2	1.5	49	28	41	M6x0.75	14	5	4	49	3	43	0.30	215	12
H650T-M36x...W	M36	4	3	1.5	53	28	44	M6x0.75	16	5	4	53	6	46	0.35	255	12
H650T-M39x...W	M39	4	3	1.5	61	38	50	M8x1	10	6	5	61	4	57	0.60	300	30
H650T-M42x...W	M42	4.5	3	1.5	64	38	53	M8x1	12	6	5	64	4	57	0.65	350	30
H650T-M45x...W	M45	4.5	3	1.5	67	38	56	M8x1	14	6	5	67	6	59	0.75	405	29
H650T-M48x...W	M48	5	3	1.5	72	38	59	M8x1	14	6	5	70	10	63	0.90	455	33
H650T-M52x...W	M52	5	3	2	79	46	66	M10x1.25	12	8	6	78	5	69	1.25	540	56
H650T-M56x...W	M56	5.5	4	2	84	46	70	M10x1.25	14	8	6	82	10	74	1.45	630	57
H650T-M60x...W	M60	5.5	4	2	90	46	74	M10x1.25	16	8	6	86	14	78	1.75	740	58
H650T-M64x...W	M64	6	4	2	96	62	80	M12x1.25	12	10	8	96	18	102	2.75	830	105
H650T-M72x...W	M72	6	4	2	106	62	88	M12x1.25	16	10	8	105	6	90	2.80	1070	100
H650T-M76x...W	M76	6	4	2	114	62	96	M12x1.25	16	10	8	112	12	96	3.50	1200	110
H650T-M80x...W	M80	6	4	2	118	62	96	M12x1.25	18	10	8	112	15	99	3.70	1330	110
H650T-M90x...W	M90	6	4	2	135	80	111	M16x1.5	14	14	9	135	9	117	6.10	1730	245
H650T-M100x...W	M100	6	4	2	149	80	121	M16x1.5	16	14	9	144	19	127	7.85	2170	270

IMPERIAL	Size				Nut body			Jackbolt				Hardened washer		Height tot. L [in]	Weight [Lb]	Preload total nom. F <sub>1</sub> [Lb]	Torque per Jackbolt nom. M <sub>1</sub> [Lbft]
	Part No.	Thread D [in]	Available TPI TPI <sub>1</sub> TPI <sub>2</sub> TPI <sub>3</sub>			D <sub>1</sub>	H [in]	D <sub>T</sub>	D <sub>j</sub>	n	SW [in]	a	D <sub>s</sub>				
H650T-100-...W	1	8	12	14	1.67	1.10	1.34	1/4-28	8	3/16	0.18	1.67	0.13	1.72	0.53	27260	9
H650T-112-...W	1-1/8	7	8	12	1.80	1.10	1.46	1/4-28	8	3/16	0.18	1.75	0.13	1.72	0.58	35570	12
H650T-125-...W	1-1/4	7	8	12	1.92	1.10	1.59	1/4-28	12	3/16	0.18	1.88	0.13	1.72	0.64	44990	10
H650T-137-...W	1-3/8	6	8	12	2.08	1.10	1.71	1/4-28	14	3/16	0.18	2.05	0.25	1.84	0.80	55510	11
H650T-150-...W	1-1/2	6	8	12	2.34	1.50	1.92	5/16-24	10	1/4	0.20	2.29	0.15	2.24	1.17	67130	22
H650T-162-...W	1-5/8	6	8	12	2.47	1.50	2.05	5/16-24	12	1/4	0.20	2.47	0.15	2.24	1.26	79860	22
H650T-175-...W	1-3/4	5	8	12	2.62	1.50	2.17	5/16-24	14	1/4	0.20	2.60	0.25	2.34	1.46	93700	22
H650T-187-...W	1-7/8	6	8	12	2.79	1.50	2.30	5/16-24	16	1/4	0.20	2.75	0.38	2.47	1.75	108600	22
H650T-200-...W	2	4.5	8	12	3.06	1.80	2.51	3/8-24	12	5/16	0.25	3.00	0.20	2.73	2.45	124700	41
H650T-225-...W	2-1/4	4.5	8	12	3.37	1.80	2.76	3/8-24	16	5/16	0.25	3.26	0.40	2.93	3.12	160100	40
H650T-250-...W	2-1/2	4	8	12	3.75	2.10	3.09	7/16-20	16	3/8	0.25	3.68	0.40	3.29	4.38	199900	58
H650T-275-...W	2-3/4	4	8	12	4.13	2.50	3.43	1/2-20	14	7/16	0.30	4.12	0.25	3.65	5.92	244100	91
H650T-300-...W	3	4	6	8	4.49	2.50	3.68	1/2-20	16	7/16	0.30	4.40	0.50	3.90	7.50	292800	95
H650T-325-...W	3-1/4	4	6	8	4.87	2.50	3.93	1/2-20	18	7/16	0.30	4.65	0.70	4.10	9.21	345900	100
H650T-350-...W	3-1/2	4	6	8	5.30	3.15	4.34	5/8-18	14	9/16	0.35	5.19	0.35	4.60	12.69	403300	188
H650T-375-...W	3-3/4	4	6	8	5.62	3.15	4.59	5/8-18	16	9/16	0.35	5.60	0.60	4.85	15.11	465300	189
H650T-400-...W	4	4	6	8	5.97	3.15	4.84	5/8-18	18	9/16	0.35	5.69	0.80	5.05	17.26	531600	192

Note: - Other sizes, thread pitches or threads per inch (TPI) may be available. Please contact your local Nord-Lock office.  
- Dimensions listed are representative. Typical manufacturing tolerances apply (approximately within 1mm or 1%).

# SJ

## Superbolt nut-style tensioner, compact

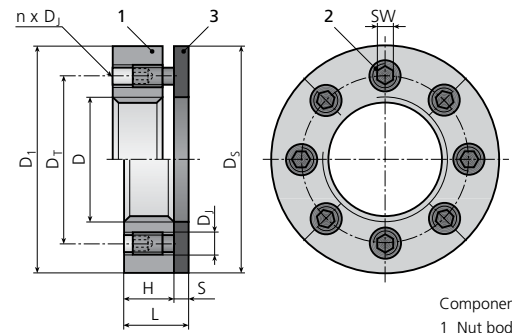

- Components:  
 1 Nut body  
 2 Jackbolts  
 3 Hardened washer

METRIC Part No.	Size			Nut body			Jackbolt			Hardened washer		Height tot. L [mm]	Weight [kg]	Preload total		Torque per Jackbolt		
	Thread D	Available Pitch P <sub>1</sub> P <sub>2</sub> P <sub>3</sub> [mm]			D <sub>1</sub>	H [mm]	D <sub>T</sub>	D <sub>j</sub> [mm]	n	SW [mm]	D <sub>s</sub> [mm]			S	nom. F <sub>1</sub>	max. F <sub>2</sub>	nom. M <sub>1</sub>	max. M <sub>2</sub>
SJ-M20x...W	M20	2.5	1.5	1	43	15	32	M8x1	6	4	43	4	19	0.15	67	91	11	15
SJ-M22x...W	M22	2.5	1.5	1	47	16	34	M8x1	8	4	45	5	21	0.20	81	105	10	13
SJ-M24x...W	M24	3	2	1.5	50	16	36	M8x1	8	4	48	5	21	0.20	89	120	11	15
SJ-M27x...W	M27	3	2	1.5	53	16	39	M8x1	10	4	50	5	21	0.25	100	130	10	13
SJ-M30x...W	M30	3.5	2	1.5	60	21	45	M10x1.25	8	5	59	5	26	0.40	135	180	21	28
SJ-M33x...W	M33	3.5	2	1.5	63	22	48	M10x1.25	10	5	63	5	27	0.40	155	200	19	25
SJ-M36x...W	M36	4	3	1.5	69	28	54	M12x1.25	8	6	69	5	33	0.65	190	245	35	46
SJ-M39x...W	M39	4	3	1.5	75	28	57	M12x1.25	10	6	75	5	33	0.80	255	335	38	50
SJ-M42x...W	M42	4.5	3	1.5	81	28	60	M12x1.25	12	6	78	5	33	0.90	315	420	39	52
SJ-M45x...W	M45	4.5	3	1.5	88	28	63	M12x1.25	12	6	81	6	34	1.00	315	420	39	52
SJ-M48x...W	M48	5	3	1.5	101	31	71	M16x1.5	8	8	94	6	37	1.65	380	500	94	125
SJ-M52x...W	M52	5	3	2	101	33	75	M16x1.5	8	8	94	6	39	1.65	380	500	94	125
SJ-M56x...W	M56	5.5	4	2	113	33	79	M16x1.5	12	8	100	6	39	2.05	570	760	94	125
SJ-M60x...W	M60	5.5	4	2	117	33	83	M16x1.5	12	8	106	6	39	2.15	570	760	94	125
SJ-M64x...W	M64	6	4	2	119	33	87	M16x1.5	12	8	120	8	41	2.45	570	760	94	125
SJ-M68x...W	M68	6	4	2	138	38	97	M20x1.5	12	10	125	8	46	3.60	710	950	145	195
SJ-M72x...W	M72	6	4	2	151	38	101	M20x1.5	12	10	125	8	46	4.50	910	1200	185	245
SJ-M76x...W	M76	6	4	2	151	38	105	M20x1.5	12	10	138	8	46	4.35	860	1130	175	230
SJ-M80x...W	M80	6	4	2	158	38	109	M20x1.5	12	10	145	10	48	4.95	910	1200	185	245
SJ-M90x...W	M90	6	4	2	170	51	125	M24x2	12	12	160	10	61	7.20	1160	1530	280	370
SJ-M100x...W	M100	6	4	2	177	53	135	M24x2	12	12	180	10	63	7.75	1160	1530	280	370
SJ-M110x...W	M110	6	4	2	190	59	145	M24x2	16	12	190	10	69	9.25	1550	2040	280	370
SJ-M120x...W	M120	6	4	2	202	59	155	M24x2	16	12	202	10	69	10.25	1550	2040	280	370
SJ-M125x...W	M125	6	4	2	205	59	160	M24x2	16	12	202	10	69	10.25	1550	2040	280	370
SJ-M130x...W	M130	6	4	2	210	59	165	M24x2	16	12	202	10	69	10.50	1550	2040	280	370
SJ-M140x...W	M140	6	4	2	221	59	175	M24x2	16	12	215	12	71	11.75	1550	2040	280	370
SJ-M150x...W	M150	6	4	2	230	59	185	M24x2	16	12	225	12	71	12.25	1550	2040	280	370
SJ-M160x...W	M160	6	4	-	240	59	195	M24x2	16	12	240	12	71	13.25	1550	2040	280	370

IMPERIAL Part No.	Size			Nut body			Jackbolt			Hardened washer		Height tot. L [in]	Weight [Lb]	Preload total		Torque per Jackbolt		
	Thread D [in]	Available TPI TPI <sub>1</sub> TPI <sub>2</sub> TPI <sub>3</sub>			D <sub>1</sub>	H [in]	D <sub>T</sub>	D <sub>j</sub> [in]	n	SW [in]	D <sub>s</sub> [in]			S	nom. F <sub>1</sub>	max. F <sub>2</sub>	nom. M <sub>1</sub>	max. M <sub>2</sub>
SJ-075-...W	3/4	10	16	-	1.70	0.55	1.19	5/16-24	4	5/32	1.63	0.13	0.68	0.34	16281	21708	9	12
SJ-087-...W	7/8	9	14	-	1.84	0.60	1.31	5/16-24	6	5/32	1.75	0.13	0.73	0.40	21708	28944	9	12
SJ-100-...W	1	8	12	14	1.95	0.60	1.44	5/16-24	8	5/32	2.00	0.19	0.79	0.49	21708	28944	9	12
SJ-112-...W	1-1/8	7	8	12	2.20	0.80	1.65	3/8-24	6	3/16	2.13	0.19	0.99	0.67	30012	40016	15	20
SJ-125-...W	1-1/4	7	8	12	2.34	0.80	1.78	3/8-24	8	3/16	2.38	0.19	0.99	0.85	30012	40016	15	20
SJ-137-...W	1-3/8	6	8	12	2.45	0.92	1.90	3/8-24	10	3/16	2.50	0.19	1.11	0.96	37515	50020	15	20
SJ-150-...W	1-1/2	6	8	12	2.95	1.10	2.20	1/2-20	8	1/4	2.75	0.19	1.29	1.67	56940	75920	37	49
SJ-162-...W	1-5/8	6	8	12	3.20	1.10	2.33	1/2-20	8	1/4	2.88	0.19	1.29	1.92	71175	94900	37	49
SJ-175-...W	1-3/4	5	8	12	3.45	1.10	2.45	1/2-20	10	1/4	3.45	0.25	1.35	2.33	85410	113880	37	49
SJ-187-...W	1-7/8	6	8	12	3.59	1.10	2.58	1/2-20	12	1/4	3.59	0.25	1.35	2.57	85410	113880	37	49
SJ-200-...W	2	4.5	8	12	3.95	1.30	2.88	5/8-11	8	5/16	3.50	0.25	1.55	3.63	91392	121856	75	99
SJ-225-...W	2-1/4	4.5	8	12	4.45	1.30	3.13	5/8-11	10	5/16	4.00	0.25	1.55	4.57	137088	182784	75	99
SJ-250-...W	2-1/2	4	8	12	4.70	1.30	3.38	5/8-11	12	5/16	4.50	0.31	1.61	5.25	137088	182784	75	99
SJ-275-...W	2-3/4	4	8	12	5.45	1.50	3.80	3/4-10	12	3/8	4.75	0.31	1.81	7.65	165798	221064	119	159
SJ-300-...W	3	4	6	8	5.95	1.90	4.23	7/8-9	12	1/2	5.25	0.38	2.28	12.55	226260	301680	179	238
SJ-325-...W	3-1/4	4	6	8	6.20	1.90	4.48	7/8-9	12	1/2	5.50	0.38	2.28	12.10	226260	301680	179	238
SJ-350-...W	3-1/2	4	6	8	6.45	1.90	4.73	7/8-9	12	1/2	5.75	0.38	2.28	12.72	226260	301680	179	238
SJ-375-...W	3-3/4	4	6	8	6.70	2.00	4.98	7/8-9	14	1/2	6.00	0.38	2.38	15.02	226260	301680	179	238
SJ-400-...W	4	4	6	8	6.95	2.00	5.23	7/8-9	12	9/16	6.65	0.38	2.38	15.89	226260	301680	179	238
SJ-425-...W	4-1/4	4	6	8	7.20	2.30	5.48	7/8-9	14	9/16	6.90	0.38	2.68	16.63	301680	402240	179	238
SJ-450-...W	4-1/2	4	6	8	7.45	2.30	5.73	7/8-9	14	9/16	7.40	0.38	2.68	19.07	301680	402240	179	238
SJ-475-...W	4-3/4	4	6	8	7.70	2.30	5.98	7/8-9	16	9/16	7.90	0.38	2.68	20.63	301680	402240	179	238
SJ-500-...W	5	4	6	8	7.95	2.30	6.23	7/8-9	16	9/16	7.90	0.38	2.68	21.19	301680	402240	179	238
SJ-525-...W	5-1/4	4	6	8	8.70	2.40	6.65	1-8	16	9/16	8.40	0.50	2.90	28.11	396720	528960	269	358
SJ-550-...W	5-1/2	4	6	8	8.95	2.40	6.90	1-8	16	9/16	8.40	0.50	2.90	28.75	396720	528960	269	358
SJ-575-...W	5-3/4	4	6	8	9.20	2.40	7.15	1-8	16	9/16	9.40	0.50	2.90	31.41	396720	528960	269	358
SJ-600-...W	6	4	6	8	9.45	2.40	7.40	1-8	16	9/16	9.40	0.50	2.90	31.38	396720	528960	269	358

Note: - Maximum values valid for permanent bolting applications, including reaction forces.  
 - Other sizes, thread pitches or threads per inch (TPI) may be available. Please contact your local Nord-Lock office.  
 - Dimensions listed are representative. Typical manufacturing tolerances apply (approximately within 1mm or 1%).



# Bolt-style tensioners



Superbolt bolt-style tensioners are used in a wide variety of applications where a nut-style tensioner and stud combination does not fit or is not the preferred solution.

## Incorporating multi-jackbolt technology into a bolt:

- Has all of the preload and low torque advantages of the MJT nuts.
- Requires less head diameter and therefore less space than nut-style MJTs.
- Reduces the number of parts versus stud and nuts.
- Small head dimensions can fit into tight countersinks or space restrictions.

Dimensions for SB8 (bolt-style tensioners) and SB12 (high strength bolt-style tensioners) are available on pages 18 & 19.

# Flexnuts for through hole applications

For through hole applications we have developed the Superbolt Flexnut, which is a reactive nut that is able to flex elastically. Putting a Flexnut gives the same advantages as the MJT on the reactive side. Under load they flex at the bottom and at the top. This helps relieve stress concentrations and increases the fatigue life of the stud/bolt. Since Flexnuts are reactive nuts to be used opposite our tensioners, they are never torqued directly to achieve preload.

## Advantages with Superbolt Flexnuts:

- Under load they ensure an equal load distribution on the thread of the bolt / stud.
- Adds elasticity in the joint.
- Increases the fatigue life of the bolt / stud.

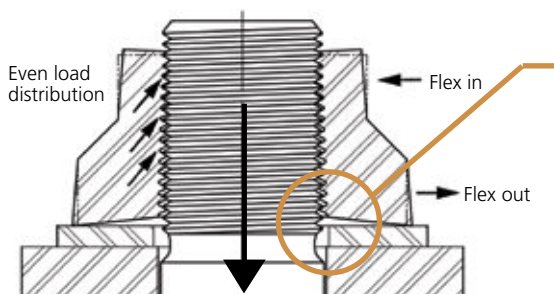

Reduced stress concentrations in the first few threads. Angled face of nut flattens out after tightening.

*[flexing shown exaggerated]*

Load applied by Superbolt tensioner on opposite end.



Split gear segment on rotary kiln.

Dimension lists for SX8 and SX12 (high strength) are available on pages 20 & 21.



# SB12

Superbolt bolt-style tensioner,  
high strength

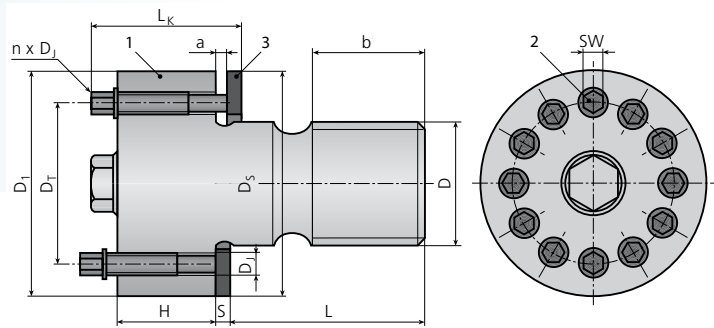

- Components:  
 1 Bolt body  
 2 Jackbolts  
 3 Hardened washer  
 $b = 2 \times D$   
 L = Length information required

METRIC	Size			Bolt body			Jackbolt				Hardened washer		Height tot. $L_k$ [mm]	Preload total		Torque per Jackbolt		
	Part No.	Thread D	Available Pitch $P_1$ $P_2$ $P_3$ [mm]	$D_1$	H	$D_t$	$D_j$ [mm]	n	SW	a [mm]	$D_s$ [mm]	S		nom. $F_1$	max. $F_2$	nom. $M_1$	max. $M_2$	
SB12-M20x...x.../W	M20	2.5	1.5	1	35	18	26	M6x0.75	8	5	4	35	4	33	146	187	14	18
SB12-M24x...x.../W	M24	3	2	1.5	43	24	32	M8x1	6	6	6	43	4	44	202	268	34	45
SB12-M27x...x.../W	M27	3	2	1.5	47	24	35	M8x1	8	6	6	47	5	45	270	357	34	45
SB12-M30x...x.../W	M30	3.5	2	1.5	50	24	38	M8x1	10	6	6	50	5	45	317	427	32	43
SB12-M33x...x.../W	M33	3.5	2	1.5	57	28	43	M10x1.25	8	8	7	57	5	52	406	539	64	85
SB12-M36x...x.../W	M36	4	3	1.5	60	28	46	M10x1.25	10	8	7	60	5	52	508	675	64	85
SB12-M39x...x.../W	M39	4	3	1.5	63	28	49	M10x1.25	12	8	7	63	5	52	570	760	60	80
SB12-M42x...x.../W	M42	4.5	3	1.5	66	28	52	M10x1.25	12	8	7	66	5	52	645	855	68	90
SB12-M45x...x.../W	M45	4.5	3	1.5	75	37	57	M12x1.25	10	10	7	75	6	64	760	1020	114	152
SB12-M48x...x.../W	M48	5	3	1.5	78	37	60	M12x1.25	10	10	7	78	6	64	855	1140	128	170
SB12-M52x...x.../W	M52	5	3	2	82	37	64	M12x1.25	12	10	7	82	6	64	995	1320	124	165
SB12-M56x...x.../W	M56	5.5	4	2	86	37	68	M12x1.25	12	10	7	86	6	64	995	1320	124	165
SB12-M60x...x.../W	M60	5.5	4	2	90	37	72	M12x1.25	14	10	7	90	6	64	1160	1540	124	165
SB12-M64x...x.../W	M64	6	4	2	103	46	80	M16x1.5	10	14	10	103	8	83	1310	1740	260	345
SB12-M68x...x.../W	M68	6	4	2	107	46	84	M16x1.5	10	14	10	107	8	83	1480	1990	295	395
SB12-M72x...x.../W	M72	6	4	2	111	56	88	M16x1.5	12	14	9	111	8	92	1690	2260	280	375
SB12-M76x...x.../W	M76	6	4	2	116	56	92	M16x1.5	14	14	9	116	8	92	1900	2540	270	360
SB12-M80x...x.../W	M80	6	4	2	120	56	96	M16x1.5	14	14	9	120	8	92	2110	2820	300	400
SB12-M90x...x.../W	M90	6	4	2	139	61	110	M20x1.5	12	17	9	139	10	99	2740	3660	560	750

IMPERIAL	Size			Bolt body			Jackbolt				Hardened washer		Height tot. $L_k$ [in]	Preload total		Torque per Jackbolt		
	Part No.	Thread D [in]	Available TPI $TPI_1$ $TPI_2$ $TPI_3$	$D_1$	H [in]	$D_t$	$D_j$ [in]	n	SW [in]	a [in]	$D_s$ [in]	S		nom. $F_1$	max. $F_2$	nom. $M_1$	max. $M_2$	
SB12-075-...x.../W	3/4	10	16	-	1.35	.70	1.00	1/4-28	6	3/16	0.24	1.35	0.13	1.38	27180	36240	12	16
SB12-087-...x.../W	7/8	9	14	-	1.48	.70	1.13	1/4-28	8	3/16	0.24	1.48	0.13	1.38	37710	50280	13	17
SB12-100-...x.../W	1	8	12	14	1.73	.90	1.31	5/16-24	6	1/4	0.24	1.73	0.16	1.68	49590	66120	28	37
SB12-112-...x.../W	1-1/8	7	8	12	1.85	.90	1.44	5/16-24	8	1/4	0.23	1.83	0.16	1.68	65520	87360	27	36
SB12-125-...x.../W	1-1/4	7	8	12	1.98	.90	1.56	5/16-24	12	1/4	0.23	1.98	0.16	1.68	83610	111480	23	31
SB12-137-...x.../W	1-3/8	6	8	12	2.23	1.10	1.75	3/8-24	10	5/16	0.25	2.23	0.20	2.03	103950	138600	41	55
SB12-150-...x.../W	1-1/2	6	8	12	2.35	1.10	1.88	3/8-24	12	5/16	0.25	2.35	0.20	2.03	126000	168000	42	55
SB12-162-...x.../W	1-5/8	6	8	12	2.47	1.10	2.00	3/8-24	12	5/16	0.25	2.47	0.20	2.03	151200	201600	50	67
SB12-175-...x.../W	1-3/4	5	8	12	2.73	1.40	2.19	7/16-20	12	3/8	0.30	2.73	0.25	2.49	178200	237600	69	92
SB12-187-...x.../W	1-7/8	6	8	12	2.98	1.50	2.38	1/2-20	10	7/16	0.30	2.98	0.25	2.60	207000	276000	108	144
SB12-200-...x.../W	2	4.5	8	12	3.20	1.50	2.50	1/2-20	12	7/16	0.30	3.20	0.25	2.60	238500	318000	103	138
SB12-225-...x.../W	2-1/4	4.5	8	12	3.45	1.60	2.75	1/2-20	12	7/16	0.30	3.45	0.25	2.85	256500	342000	111	148
SB12-250-...x.../W	2-1/2	4	8	12	3.95	1.80	3.13	5/8-18	10	9/16	0.40	3.94	0.31	3.26	321750	429000	210	279
SB12-275-...x.../W	2-3/4	4	8	12	4.20	2.20	3.38	5/8-18	12	9/16	0.40	4.20	0.31	3.61	394500	526000	214	285
SB12-300-...x.../W	3	4	6	8	4.45	2.20	3.63	5/8-18	14	9/16	0.40	4.45	0.31	3.61	474000	632000	220	294
SB12-325-...x.../W	3-1/4	4	6	8	4.95	2.35	4.00	3/4-16	12	5/8	0.35	4.95	0.38	4.01	561750	749000	362	483
SB12-350-...x.../W	3-1/2	4	6	8	5.20	2.35	4.25	3/4-16	14	5/8	0.35	5.20	0.38	4.01	656250	875000	363	484

- Note:
- Maximum values valid for permanent bolting applications, including reaction forces.
  - Overall weight will vary with length.
  - Other sizes, thread pitches or threads per inch (TPI) may be available. Please contact your local Nord-Lock office.
  - Dimensions listed are representative. Typical manufacturing tolerances apply (approximately within 1mm or 1%).

# SX8

Superbolt Flexnut,  
standard

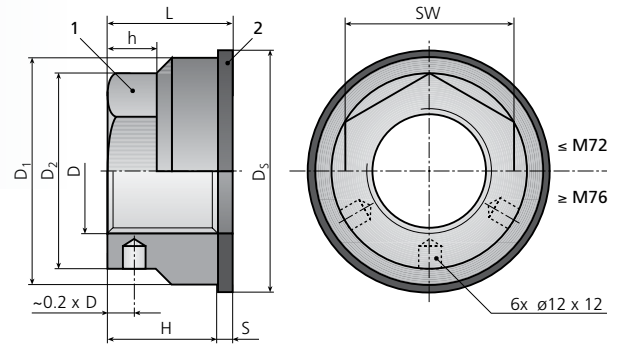

Components:

- 1 Nut body
- 2 Hardened washer

METRIC	Size			Nut body					Hardened washer		Height	Weight	Preload total		
	Part No.	Thread D	Available Pitch P <sub>1</sub> P <sub>2</sub> P <sub>3</sub> [mm]	D <sub>1</sub>	H	D <sub>2</sub> [mm]	h	SW	D <sub>s</sub> [mm]	S			tot. L [mm]	[kg]	nom. F <sub>1</sub> [kN]
SX8-M20x...W	M20	2.5	1.5	1	35	17	30	8	27	38	4	21	0.10	110	140
SX8-M24x...W	M24	3	2	1.5	42	20	37	10	33	45	4	24	0.15	145	187
SX8-M27x...W	M27	3	2	1.5	47	23	40	11	36	50	5	28	0.20	214	285
SX8-M30x...W	M30	3.5	2	1.5	52	25	43	12	39	56	5	30	0.25	214	285
SX8-M33x...W	M33	3.5	2	1.5	57	28	47	13	42	63	6	34	0.40	285	380
SX8-M36x...W	M36	4	3	1.5	62	31	53	14	48	69	6	37	0.50	343	457
SX8-M39x...W	M39	4	3	1.5	66	33	56	15	51	72	6	39	0.60	457	610
SX8-M42x...W	M42	4.5	3	1.5	73	36	62	17	56	76	6	42	0.75	457	610
SX8-M45x...W	M45	4.5	3	1.5	77	38	64	18	57	81	6	44	0.85	700	935
SX8-M48x...W	M48	5	3	1.5	83	41	71	19	64	86	6	47	1.10	700	935
SX8-M52x...W	M52	5	3	2	88	44	74	21	67	94	6	50	1.25	700	935
SX8-M56x...W	M56	5.5	4	2	97	48	80	22	72	100	6	54	1.60	875	1160
SX8-M60x...W	M60	5.5	4	2	105	51	84	23	76	110	8	59	2.05	875	1160
SX8-M64x...W	M64	6	4	2	111	54	88	26	80	120	8	62	2.35	1270	1690
SX8-M72x...W	M72	6	4	2	125	61	98	29	90	130	8	69	3.15	1270	1690
SX8-M76x...W	M76	6	4	2	132	64	109	30	—*	138	10	74	4.20	1900	2530
SX8-M80x...W	M80	6	4	2	139	68	120	32	—*	145	10	78	5.20	1900	2530
SX8-M90x...W	M90	6	4	2	156	76	135	36	—*	160	10	86	7.10	2530	3380
SX8-M100x...W	M100	6	4	2	173	85	150	40	—*	180	10	95	9.70	2530	3380
SX8-M110x...W	M110	6	4	2	191	94	165	44	—*	202	10	104	13.00	3150	4200
SX8-M120x...W	M120	6	4	2	208	102	180	48	—*	215	12	114	16.75	4200	5600
SX8-M125x...W	M125	6	4	2	218	108	188	51	—*	227	12	120	19.50	4200	5600
SX8-M130x...W	M130	6	4	2	226	111	195	52	—*	234	12	123	21.25	4700	6300
SX8-M140x...W	M140	6	4	2	243	119	210	56	—*	253	12	131	26.25	5250	7000
SX8-M150x...W	M150	6	4	2	260	127	225	60	—*	271	12	139	31.75	5250	7000
SX8-M160x...W	M160	6	4	-	278	136	240	64	—*	290	12	148	38.75	6300	8400

IMPERIAL	Size			Nut body					Hardened washer		Height	Weight	Preload total		
	Part No.	Thread D [in]	Available TPI TPI <sub>1</sub> TPI <sub>2</sub> TPI <sub>3</sub>	D <sub>1</sub>	H	D <sub>2</sub> [in]	h	SW	D <sub>s</sub> [in]	S			tot. L [in]	[Lb]	nom. F <sub>1</sub> [Lb]
SX8-075...W	3/4	10	16	-	1.30	0.64	1.11	0.30	1	1.50	0.13	0.77	0.17	20400	27200
SX8-087...W	7/8	9	14	-	1.52	0.74	1.25	0.35	1-1/8	1.62	0.13	0.87	0.23	30600	40800
SX8-100...W	1	8	12	14	1.73	0.85	1.46	0.40	1-5/16	2.00	0.60	1.01	0.38	48600	64800
SX8-112...W	1-1/8	7	8	12	1.95	0.96	1.67	0.45	1-1/2	2.12	0.16	1.12	0.52	48600	64800
SX8-125...W	1-1/4	7	8	12	2.17	1.06	1.81	0.50	1-5/8	2.50	0.19	1.25	0.73	64800	86400
SX8-137...W	1-3/8	6	8	12	2.38	1.17	1.94	0.55	1-3/4	2.50	0.19	1.36	0.87	73800	98400
SX8-150...W	1-1/2	6	8	12	2.60	1.28	2.22	0.60	2	3.00	0.25	1.53	1.33	98400	131200
SX8-162...W	1-5/8	6	8	12	2.81	1.38	2.36	0.65	2-1/8	3.00	0.25	1.63	1.54	98400	131200
SX8-175...W	1-3/4	5	8	12	3.03	1.49	2.50	0.70	2-1/4	3.25	0.25	1.74	1.85	129600	172800
SX8-187...W	1-7/8	6	8	12	3.25	1.59	2.78	0.75	2-1/2	3.50	0.25	1.84	2.54	175200	233600
SX8-200...W	2	4.5	8	12	3.46	1.70	2.92	0.80	2-5/8	3.75	0.25	1.95	2.76	175200	233600
SX8-225...W	2-1/4	4.5	8	12	3.90	1.91	3.30	0.90	3	4.22	0.31	2.22	4.07	175200	233600
SX8-250...W	2-1/2	4	8	12	4.33	2.13	3.55	1.00	3-1/4	4.70	0.31	2.44	5.31	285600	380800
SX8-275...W	2-3/4	4	8	12	4.76	2.34	3.93	1.10	3-5/8	4.95	0.31	2.65	7.46	285600	380800
SX8-300...W	3	4	6	8	5.23	2.55	4.30	1.20	4	5.45	0.38	2.93	9.18	428400	571200
SX8-325...W	3-1/4	4	6	8	5.63	2.76	4.88	1.30	4-1/2	5.95	0.38	3.14	12.08	428400	571200
SX8-350...W	3-1/2	4	6	8	6.06	2.98	5.25	1.40	4-7/8	6.45	0.38	3.36	14.98	571200	761600
SX8-375...W	3-3/4	4	6	8	6.50	3.19	5.63	1.50	5-1/4	6.94	0.38	3.57	18.36	571200	761600
SX8-400...W	4	4	6	8	6.93	3.40	6.00	1.60	5-5/8	7.45	0.43	3.83	22.55	642600	856800
SX8-425...W	4-1/4	4	6	8	7.36	3.61	6.38	1.70	5-7/8	7.95	0.43	4.04	28.55	806400	1075200
SX8-450...W	4-1/2	4	6	8	7.79	3.83	6.75	1.80	6-1/4	8.20	0.43	4.26	30.98	806400	1075200
SX8-475...W	4-3/4	4	6	8	8.23	4.04	7.13	1.90	6-5/8	8.70	0.43	4.47	38.95	907200	1209600
SX8-500...W	5	4	6	8	8.66	4.25	7.50	2.00	7	9.45	0.50	4.75	46.80	1008000	1344000
SX8-525...W	5-1/4	4	6	8	9.09	4.46	7.88	2.10	7-3/8	9.45	0.50	4.96	52.48	1108800	1478400
SX8-550...W	5-1/2	4	6	8	9.53	4.68	8.25	2.20	7-3/4	9.95	0.50	5.18	56.03	1108800	1478400
SX8-575...W	5-3/4	4	6	8	9.96	4.89	8.63	2.30	8-1/8	10.45	0.50	5.39	65.49	1209600	1612800
SX8-600...W	6	4	6	8	10.39	5.10	9.00	2.40	8-1/2	10.95	0.50	5.60	72.84	1209600	1612800

- Note:
- Maximum values valid for permanent bolting applications, including reaction forces.
  - Other sizes, thread pitches or threads per inch (TPI) may be available. Please contact your local Nord-Lock office.
  - Dimensions listed are representative. Typical manufacturing tolerances apply (approximately within 1mm or 1%).
  - \* Turning holes instead of hex flats.

# SX12

Superbolt Flexnut,  
high strength

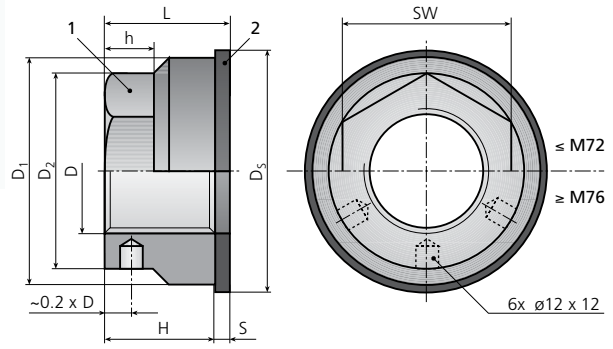

Components:

- 1 Nut body
- 2 Hardened washer

METRIC	Size			Nut body					Hardened washer		Height	Weight	Preload total		
	Part No.	Thread D	Available Pitch P <sub>1</sub> P <sub>2</sub> P <sub>3</sub> [mm]	D <sub>1</sub>	H	D <sub>2</sub> [mm]	h	SW	D <sub>s</sub> [mm]	S			tot. L [mm]	[kg]	nom. F <sub>1</sub> [kN]
SX12-M20x...W	M20	2.5	1.5	1	35	20	30	8	27	38	4	24	0.10	145	185
SX12-M24x...W	M24	3	2	1.5	42	24	37	10	33	45	4	28	0.20	215	285
SX12-M27x...W	M27	3	2	1.5	47	27	40	11	36	50	5	32	0.25	285	380
SX12-M30x...W	M30	3.5	2	1.5	52	30	43	12	39	56	5	35	0.35	285	380
SX12-M33x...W	M33	3.5	2	1.5	57	33	47	13	42	63	6	39	0.45	455	610
SX12-M36x...W	M36	4	3	1.5	62	36	53	14	48	69	6	42	0.60	455	610
SX12-M39x...W	M39	4	3	1.5	66	39	56	15	51	72	6	45	0.70	570	760
SX12-M42x...W	M42	4.5	3	1.5	73	42	62	17	56	76	6	48	0.90	685	915
SX12-M45x...W	M45	4.5	3	1.5	77	45	64	18	57	81	6	51	1.00	875	1170
SX12-M48x...W	M48	5	3	1.5	83	48	71	19	64	86	6	54	1.30	875	1170
SX12-M52x...W	M52	5	3	2	88	52	74	21	67	94	6	58	1.50	1050	1400
SX12-M56x...W	M56	5.5	4	2	97	56	80	22	72	100	6	62	1.95	1050	1400
SX12-M60x...W	M60	5.5	4	2	105	60	84	23	76	106	8	68	2.45	1580	2100
SX12-M64x...W	M64	6	4	2	111	64	88	26	80	120	8	72	2.85	1580	2100
SX12-M72x...W	M72	6	4	2	125	72	98	29	90	130	8	80	3.90	1900	2530
SX12-M76x...W	M76	6	4	2	132	76	109	30	—*	138	10	86	5.05	2530	3370
SX12-M80x...W	M80	6	4	2	139	80	120	32	—*	145	10	90	6.15	2530	3370
SX12-M90x...W	M90	6	4	2	156	90	135	36	—*	160	10	100	8.50	3150	4200
SX12-M100x...W	M100	6	4	2	173	100	150	40	—*	180	10	110	12.50	3670	4900
SX12-M110x...W	M110	6	4	2	191	110	165	44	—*	202	10	120	15.50	4200	5600
SX12-M120x...W	M120	6	4	2	208	120	180	48	—*	215	12	132	20.00	4700	6300
SX12-M125x...W	M125	6	4	2	218	125	188	51	—*	227	12	137	22.75	4700	6300
SX12-M130x...W	M130	6	4	2	226	111	195	52	—*	234	12	123	21.25	5250	7000
SX12-M140x...W	M140	6	4	2	243	119	210	56	—*	253	12	131	26.25	5750	7700
SX12-M150x...W	M150	6	4	2	260	127	225	60	—*	271	12	139	31.75	5750	7700
SX12-M160x...W	M160	6	4	-	278	136	240	64	—*	290	12	148	38.75	6300	8400

IMPERIAL	Size			Nut body					Hardened washer		Height	Weight	Preload total		
	Part No.	Thread D [in]	Available TPI TPI <sub>1</sub> TPI <sub>2</sub> TPI <sub>3</sub>	D <sub>1</sub>	H	D <sub>2</sub> [in]	h	SW	D <sub>s</sub> [in]	S			tot. L [in]	[Lb]	nom. F <sub>1</sub> [Lb]
SX12-075...W	3/4	10	16	-	1.30	0.75	1.11	0.3	1	1.50	0.13	1.01	0.15	30600	40800
SX12-087...W	7/8	9	14	-	1.52	0.88	1.25	0.35	1-1/8	1.62	0.13	1.14	0.29	40800	54400
SX12-100...W	1	8	12	14	1.73	1.00	1.46	0.4	1-5/16	2.00	0.16	1.32	0.47	48600	64800
SX12-112...W	1-1/8	7	8	12	1.95	1.13	1.67	0.45	1-1/2	2.12	0.16	1.45	0.64	64800	86400
SX12-125...W	1-1/4	7	8	12	2.17	1.25	1.81	0.5	1-5/8	2.50	0.19	1.44	0.90	73800	98400
SX12-137...W	1-3/8	6	8	12	2.38	1.38	1.94	0.55	1-3/4	2.50	0.19	1.76	1.08	98400	131200
SX12-150...W	1-1/2	6	8	12	2.60	1.50	2.22	0.6	2	3.00	0.25	2.00	1.59	129600	172800
SX12-162...W	1-5/8	6	8	12	2.81	1.63	2.36	0.65	2-1/8	3.00	0.25	2.13	1.90	129600	172800
SX12-175...W	1-3/4	5	8	12	3.03	1.75	2.5	0.7	2-1/4	3.25	0.25	2.25	2.28	194400	259200
SX12-187...W	1-7/8	6	8	12	3.25	1.88	2.78	0.75	2-1/2	3.50	0.25	2.38	2.91	175200	233600
SX12-200...W	2	4.5	8	12	3.46	2.00	2.92	0.8	2-5/8	3.75	0.25	2.50	3.43	262800	350400
SX12-225...W	2-1/4	4.5	8	12	3.90	2.25	3.3	0.9	3	4.22	0.31	2.87	5.01	262800	350400
SX12-250...W	2-1/2	4	8	12	4.33	2.50	3.55	1	3-1/4	4.70	0.31	3.12	6.51	428400	571200
SX12-275...W	2-3/4	4	8	12	4.76	2.75	3.93	1.1	3-5/8	4.95	0.31	3.37	8.42	428400	571200
SX12-300...W	3	4	6	8	5.20	3.00	4.3	1.2	4	5.45	0.38	3.76	11.33	571200	761600
SX12-325...W	3-1/4	4	6	8	5.63	3.25	4.88	1.3	4-1/2	5.95	0.38	4.01	14.93	571200	761600
SX12-350...W	3-1/2	4	6	8	6.06	3.50	5.25	1.4	4-7/8	6.45	0.38	4.26	18.27	642600	856800
SX12-375...W	3-3/4	4	6	8	6.50	3.75	5.63	1.5	5-1/4	6.95	0.38	4.51	22.61	642600	856800
SX12-400...W	4	4	6	8	6.93	4.00	6	1.6	5-5/8	7.45	0.43	4.86	27.65	714000	952000
SX12-425...W	4-1/4	4	6	8	7.36	4.25	6.38	1.7	5-7/8	7.95	0.43	5.11	32.97	907200	1209600
SX12-450...W	4-1/2	4	6	8	7.79	4.50	6.75	1.8	6-1/4	8.20	0.43	5.36	38.42	907200	1209600
SX12-475...W	4-3/4	4	6	8	8.23	4.75	7.13	1.9	6-5/8	8.70	0.43	5.61	45.09	1008000	1344000
SX12-500...W	5	4	6	8	8.66	5.00	7.5	2	7	9.45	0.50	6.00	53.75	1008000	1344000
SX12-525...W	5-1/4	4	6	8	9.09	5.25	7.88	2.1	7-3/8	9.45	0.50	6.25	60.81	1108800	1478400
SX12-550...W	5-1/2	4	6	8	9.53	5.50	8.25	2.2	7-3/4	9.95	0.50	6.50	69.67	1108800	1478400
SX12-575...W	5-3/4	4	6	8	9.96	5.75	8.63	2.3	8-1/8	10.45	0.50	6.75	79.37	1209600	1612800
SX12-600...W	6	4	6	8	10.39	6.00	9	2.4	8-1/2	10.95	0.50	7.00	89.75	1209600	1612800

- Note:
- Maximum values valid for permanent bolting applications, including reaction forces.
  - Other sizes, thread pitches or threads per inch (TPI) may be available. Please contact your local Nord-Lock office.
  - Dimensions listed are representative. Typical manufacturing tolerances apply (approximately within 1mm or 1%).
  - \* Turning holes instead of hex flats.

# Joint design and installation information



## Stud bolts

Superbolt nut-style tensioners used on studs into blind tapped holes. Tightening in pure tension means studs will not gall in the tapped hole and can be easily removed.



## Through holes

Common application of double ended studs use Superbolt nut-style tensioners and a reaction nut (Flexnut) on the other end. Flexnuts add elasticity to the stud, increasing the fatigue life.



## Tapped holes

Superbolt bolt-style tensioners are often used into blind tapped holes. MJT bolt heads are more compact and fit into tighter areas, additionally they also reduce the number of parts.



## Counter bores

Superbolt bolt-style tensioners can be provided to fit completely into small counterbores. An internal installation removal hex allows for easy turning into position.

## Instruction manual with every delivery

With Superbolt tensioners you have chosen a technologically superior product that is purely mechanical. The simple steps for installation and removal ensure correct assembly and increase safety, speed and service life.

You can additionally access this information as PDF's & video through [www.superbolt.com](http://www.superbolt.com).

For further information on possible uses, applications and maintenance of Superbolt pretensioning systems please contact your local Nord-Lock office.

## Accessories & consumables

Installation and removal can be improved with Superbolt quality accessories and consumables. They enhance product installation and removal, thereby protecting your investment in safe bolted connections. We can provide:

- Lubricants
- Protective caps
- Sockets
- Torque wrenches
- Pneumatic wrenches

The use of non-original parts can reduce the function of Superbolt tensioners considerably and can potentially cause direct as well as indirect damage.

## Installation support

You too can profit from our expertise for installation of your Superbolt tensioners. Our trained staff can provide the following service:

- Support of your staff during installation
- Installation training of your staff
- Complete installation of bolted connections

*Note: Installations performed by Nord-Lock are subject to contract.*



# Helpful tips

Important considerations when applying Superbolt multi-jackbolt tensioners for various field application scenarios.



**Centering of washer on thread**  
Make sure the washer is not resting on one side of undercuts or radius of mating studs.



**Material with low strength**  
A thicker / larger washer or an additional washer may be necessary when materials with low strength are used on the joint.



**Large or slotted holes**  
An additional washer or a large washer is necessary to transfer the bolt load to a supported surface.



**Space requirements**  
Check for space restrictions for socket and wrench combination.



**Tensioner at the end of stud**  
An additional distance spacer may be necessary to bring tensioner closer to the end of the stud for proper socket fit.



**Very long through stud**  
A special tensioner with a larger circle of jackbolts may be necessary to properly access the jackbolts for tightening.

If your application corresponds to one or more of the above mentioned design criteria, contact your local Nord-Lock office and we will help you find the best solution.

# Our engineers can **solve** your bolting challenges

## Gas Compression

Applications include: Crosshead jamnuts, counterweight crosshead jamnuts, couplings, connecting rod nuts, distance pieces, end plates, compressor cylinders, doghouse bolting, piston end nuts, valve jackbolts and more.



As seen on this reciprocating compressor distance piece, our products can be retrofitted in many limited space applications. High torque requirements can now be achieved with small hand held tools.

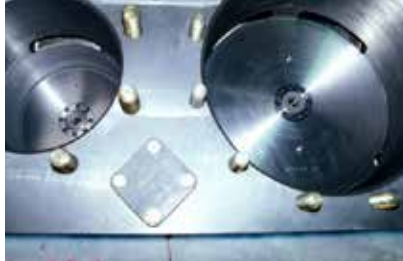

Multi-jackbolt tensioners make the installation of pistons easier. Only hand tools are required for installation and removal, and the reliability of this labyrinth-piston compressor is greatly increased over many years of usage.



Fifty-two 2" (50,8 mm) tensioners on this centrifugal compressor were tightened by two men in 2-1/2 hours. The old method required three men working an eight hour shift.

## Oil, Gas & Petrochemical

Applications include: Top drives, flame towers, blow out preventors, mud pumps, fracturing pumps, reactor covers, heat exchanger heads, turbine control valves, turbine joints, pipe flanges, anchorbolts, couplings and more.



With a 2,500 horsepower rating, and 273,000 lb (1215 kN) rod load, this Weir SPM Destiny™ Fracturing Pump utilizes Superbolt tensioners to make bolting safer and easier in the field, as only hand tools are needed.



A special multi-jackbolt tensioner series has been developed for the unique needs of the Oil & Gas industry. The washer is captive to the nut body to prevent loss of the washer, and it features corrosion protection to address the harsh conditions. Used here on a riser clamp.



Large methanol reactor with 11" (279,4 mm) studs. Six hours with Superbolt vs. two days with Hydraulic Tensioners.

## Mining

Applications include: Boom points, ring gears, side frames, hoist motors and pedestal tie-downs, draglines, pinion gears, hoist and drag drums, split gears, bolted segments, excavator bearing caps and more.

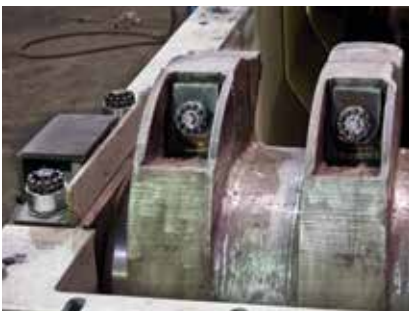

The bolting challenges on this crusher included limited space and extreme working conditions. Multi-jackbolt tensioners proved to be the ideal solution. Only 43 lb•ft (58 Nm) of torque on the jackbolts was needed, the equivalent torque on the standard bolt is 2,150 lb•ft (2915 Nm). MJTs proved to be much safer and more accurate than previous bolting methods.



Large power shovels have many critical bolting applications. Multi-jackbolt tensioners are used extensively on these machines, all over the world. Seen above, MT tensioners on a ring gear.



On these hoist & drag drums, the high preload of 428,400 lbf (1906 kN) was achieved with only 233 lb•ft (316 Nm) of torque required on each jackbolt. The added flex from the Superbolt tensioners more than doubled the elasticity of the bolted connection.



## Presses

Applications include: Press columns, tie rods, bearing blocks, high pressure piping, die cushions, cylinder ram bolting, anchorbolts and more.



The world largest bolt-style multi-jackbolt tensioner 28" diameter x 40' long (711,2 mm diameter and 12,2 m long). This was used on a large hydraulic forging press.



Eight Superbolt column nuts required only 12 man hours for installation vs. 2-1/2 full days for heating of columns.



Split-Nut thrust collars are a custom designed product from Superbolt that are much easier to install and remove than other large threaded fasteners on large press columns.

## Power Generation

Applications include: Turbine couplings, stay rods, manway doors, inlet flanges, boiler circ pump main flange, boiler feed pump head and barrel casing, blade bolts, turbine wheel to shaft bolting, pelton turbine nozzels, servo piston nuts, bearing housings and more.



Flange coupling of the gear box on a wind turbine. An expansion bolt with integrated Superbolt technology is used to transmit the enormous torque. The solution is also compact and does not add a lot of weight, which was a requirement.



Superbolt expansion bolts are ideally suited for shaft couplings, as seen here on this Francis type pump/generator shaft coupling at a pumped-storage facility.



With Superbolt tensioners, joints in awkward positions in confined spaces can be tightened. This Francis wheel has regular maintenance requirements which became manageable with MJTs connecting the wheel to the shaft.

## Steel Mills

Applications include: Thrust collars, coupling bolts, tie rod nuts, anchor bolts, mill motors, bearings, shaft mounts, roll tables, BOF and EAF applications, coilers, hydraulic cylinders, cranes, slitter knives, universal joints, back-up roll bearings, work roll bearings, pipe mills and more.



Thrust collars on bearing chocks create higher preloads than the previous method and therefore even the heaviest peakloads can be absorbed. The roll necks are lasting and the production runs smoothly.



Superbolt mill motor nuts are special jamnuts designed to fasten brake wheels, couplings, and pulleys to mill motors. They are directly interchangeable with nuts supplied by the motor manufacturers.



EAF electrode arm assembly. With the MJT, a high clamp load could be achieved to withstand the extreme vibration acting on the electrode arm.

# Your **partner** in bolting solutions

## Other technologies

The Nord-Lock Group product offering consists of several technologies, all developed and designed in-house.

## Expansion bolts

Utilizing Superbolt technology, Nord-Lock is able to offer tremendous radial expansion and joint clamping power in one bolting system. The expansion bolts replace traditional interference or force fit bolts. Radial expansion is critical for rotating couplings or alignment systems that require the bolts to be able to handle transfer of forces in shear.

The key to this technology is the split expansion sleeve that mates with the customer's machine holes, along with an internal taper that accepts a mating tapered stud. The split sleeve allows larger tolerances on mating parts than is traditionally required with interference fit or hydraulic systems, saving critical machining time.

Expansion bolts are available for blind hole and through hole applications. For more information, please visit [www.expansion-bolt.com](http://www.expansion-bolt.com).



## Wedge-locking

Our range of wedge-locking products include washers, wheel nuts, combi bolts and more. Further information is available at [www.nord-lock.com](http://www.nord-lock.com).



## Customer specials

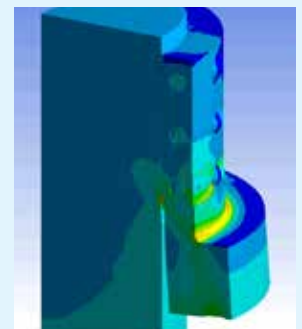

We can find the solution to any bolting problem. With a strong focus on secure and reliable joints since 1982, we have a history of thousands of special designs to prove our capabilities. We are highly adaptable to space constraints and environmental conditions that no other bolting systems can match. Lean on our experience from the beginning of your equipment design or lean on us if you have an existing bolting problem that you need to solve.



**Industry specific solutions**

We have a range of pre-engineered products that are tested and proven for specific industries, such as Oil & Gas, Steel, Mining & Quarrying and Manufacturing & Processing (e.g. chemical industry) and many more. More information available on [www.nord-lock.com](http://www.nord-lock.com).

**Performance Services**

Nord-Lock Performance Services is a partnership project offered to key customers. The purpose is to increase profitability by generating a complete and detailed view of the design of bolted connections and securing methods. As each project is designed to meet customer specific needs and challenges, both current applications and future designs can be investigated.

In addition, our global chain of services supports you throughout sourcing, design / production and aftermarket.

**Presence in your market**

The Nord-Lock Group includes subsidiaries, in-house laboratories on three continents, and a worldwide network of authorized distributors. In addition, our Field Application Engineers and Global Industry Managers with specialist skills are trained to understand your specific needs and challenges. Our philosophy is to be close to our customers, to speak your language and to help you achieve secure and effective bolted joints.

To find the complete list of Nord-Lock representatives, please go to [www.nord-lock.com/contact-us](http://www.nord-lock.com/contact-us).



**Nord-Lock global chain of services**

**Sourcing**  
Life Cycle Profitability and cost justification

Cost savings generated by optimized bolted joints.

**Design / Production**  
Field Application Engineer, Technical Centers & Project Engineering

Joint calculation and simulation. Real life testing and validation. Custom designs.

**Aftermarket**  
On-site and remote product training as well as service and retrofitting

Increasing the knowledge for operators and engineers. Installation support.

# When **safety** really matters



Joining parts together is one of the most critical steps when delivering a product or system. The Nord-Lock Group is focused on solving the toughest bolting challenges. We offer a unique combination of bolting expertise and a wide product range, including wedge-locking technologies and Superbolt tensioners — all designed and developed in-house.

Nord-Lock holds decades of documented success in every major industry, including oil and gas, energy, transportation and mining. Our Production System includes rigorous internal testing and full traceability, and our products hold several certificates from independent institutes including ABS, DIBt, DNV and TÜV.

The tools available through Nord-Lock Performance Services add value throughout a project and ensure that your bolting application pays back multiple times. We can also assist you in the design phase with joint simulation and testing. Additionally, we help you ensure successful operations over time with our onsite support and remote product training.

Our mission is to safeguard human lives and customer investments by securing the world's most demanding applications. The Nord-Lock Group looks forward to being your partner in bolting solutions.

Authorized distributor:

© Copyright 2016 Nord-Lock Group. NORD-LOCK, SUPERBOLT and BOLTIGHT are trademarks owned by different companies within the Nord-Lock Group. All other logos, trademarks, registered trademarks or service marks used herein are the property of the Nord-Lock Group. All rights reserved.